

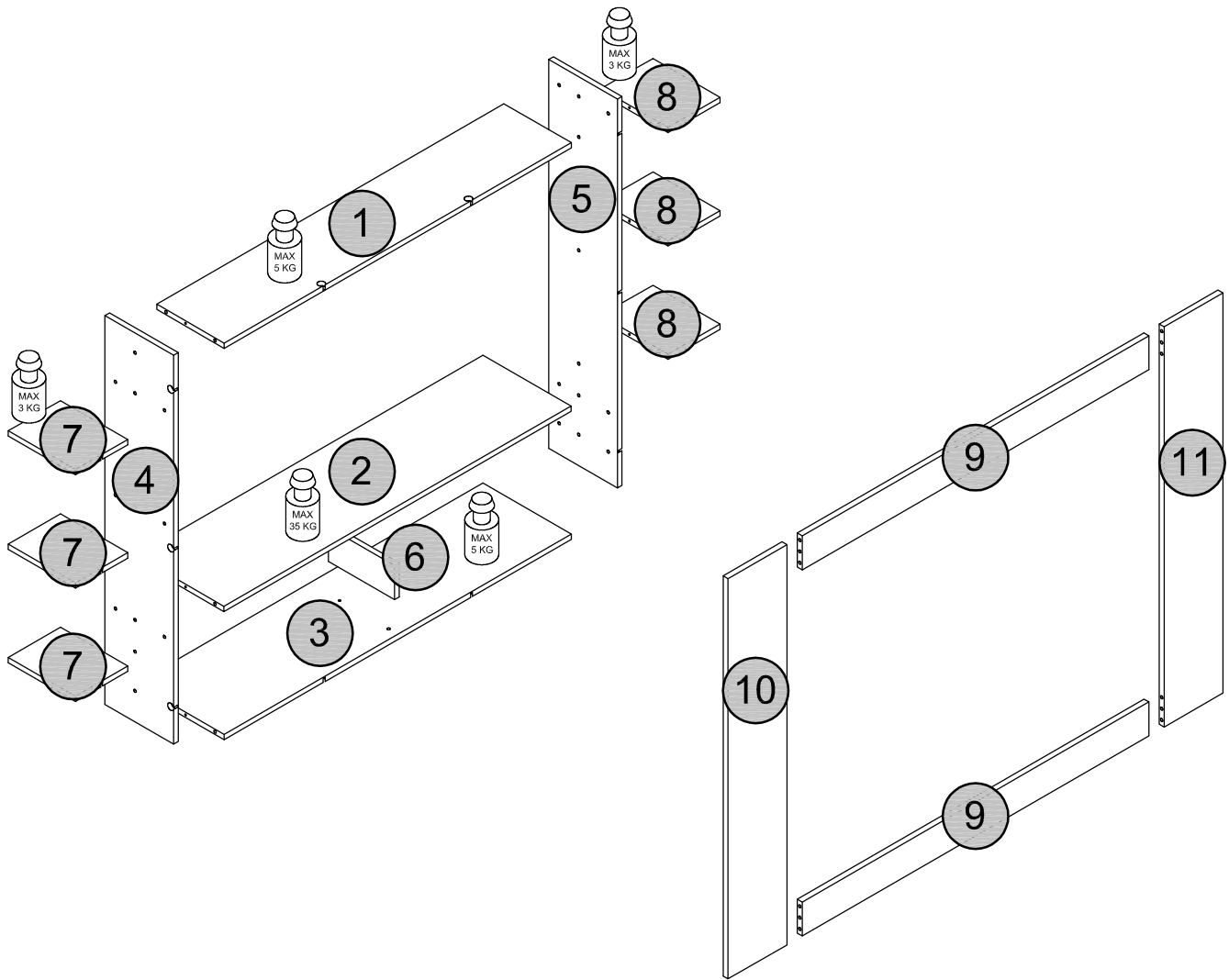









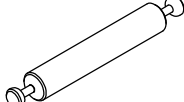
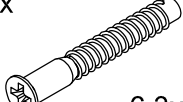

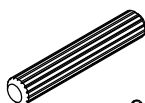
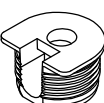
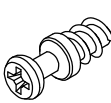
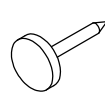
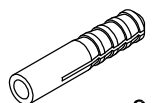
Bauteile Type: Z2.251.07 / 09

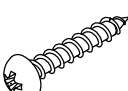

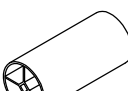
Beschlagteile Type: Z2.251.07 / 09

8x A 	4x B 	13x C  6,3x50	12x D 	8x E  8x50
24x F  8x30	16x G 	16x H 	4x I 	1x J  8x40
1x K  5x97	1x L  3,5x15	1x M  M6x60	1x N  ø40x85	8x O 

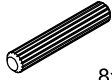
1.

24x		16x	
F	8x30	G	

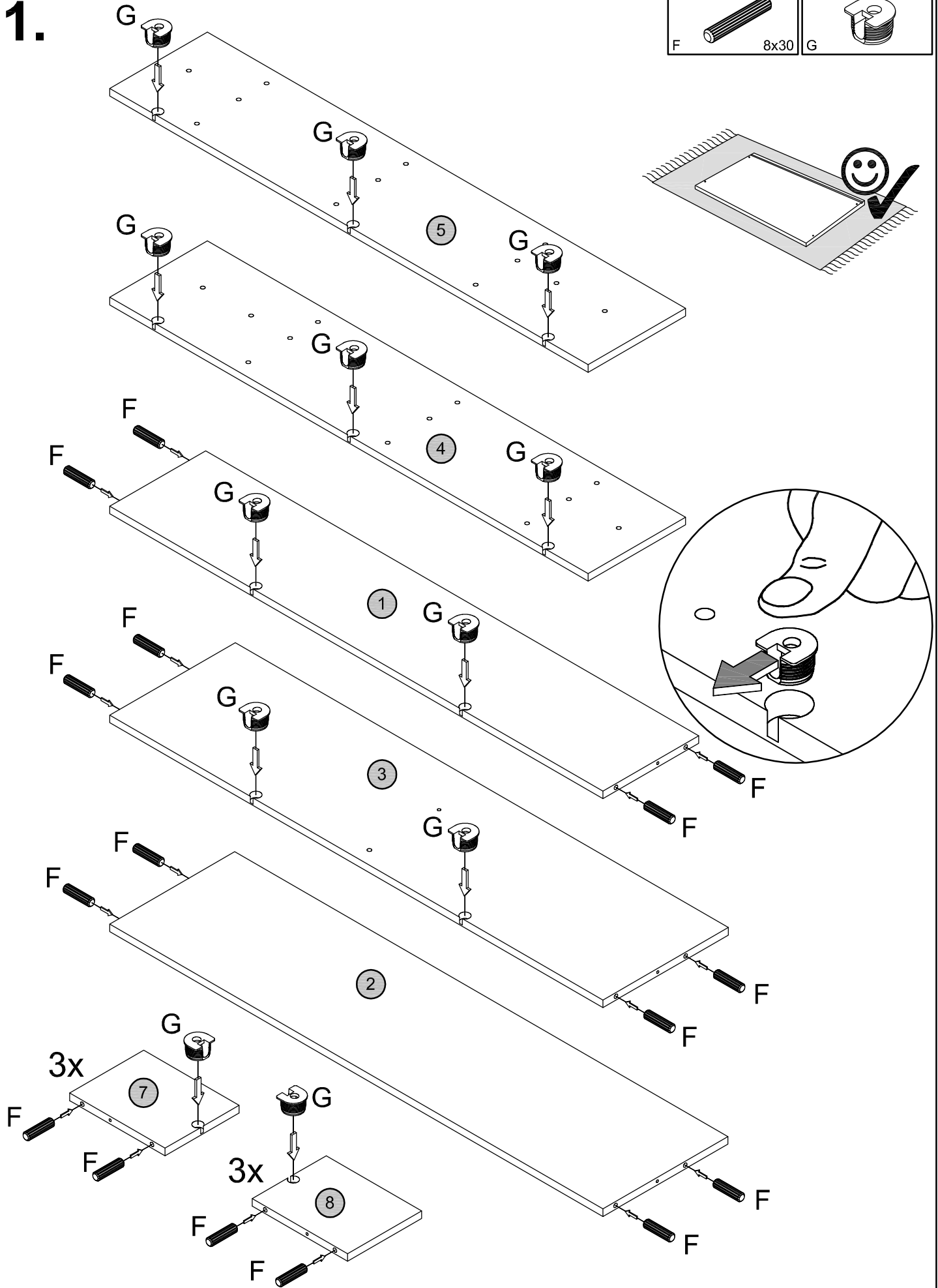
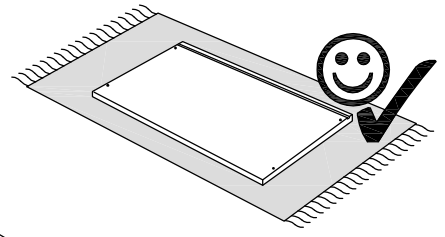

2.

8x A		8x E	
		16x H	

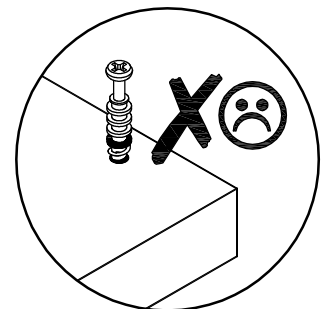
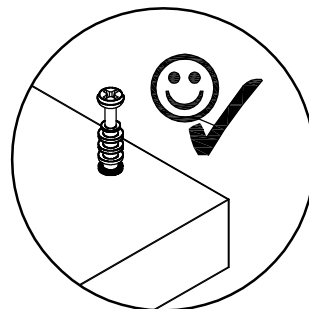
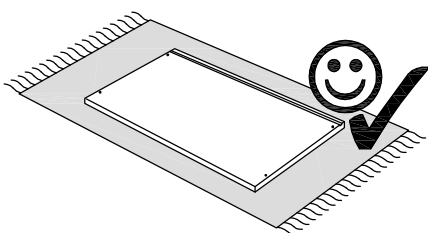
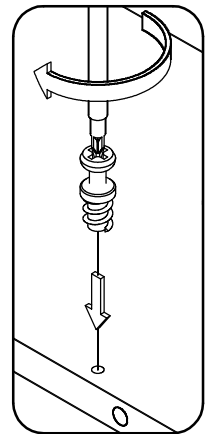
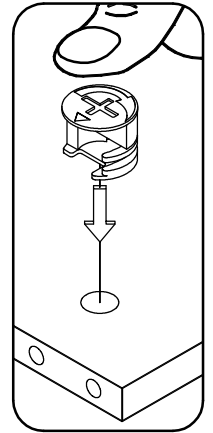
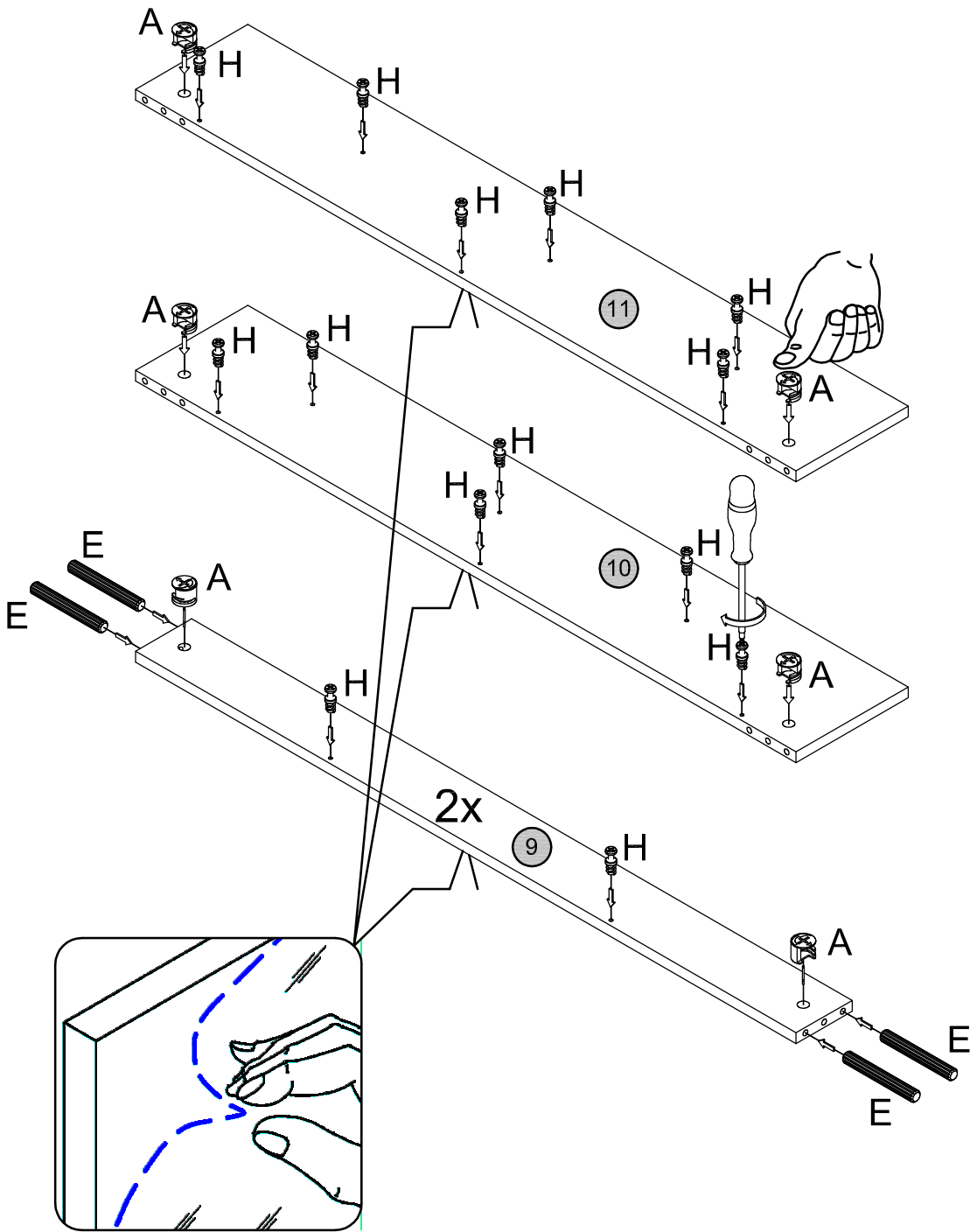

3.

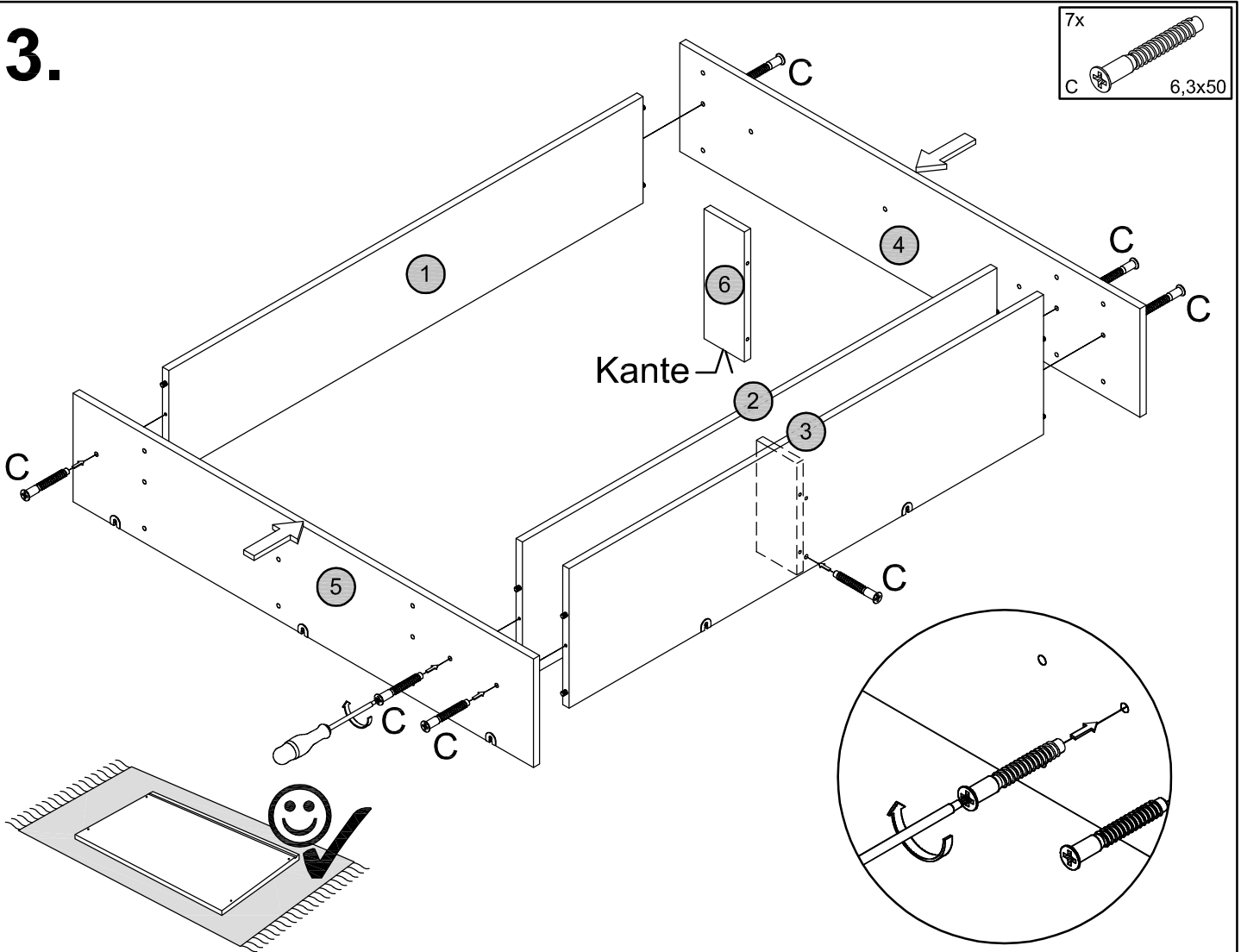

4.

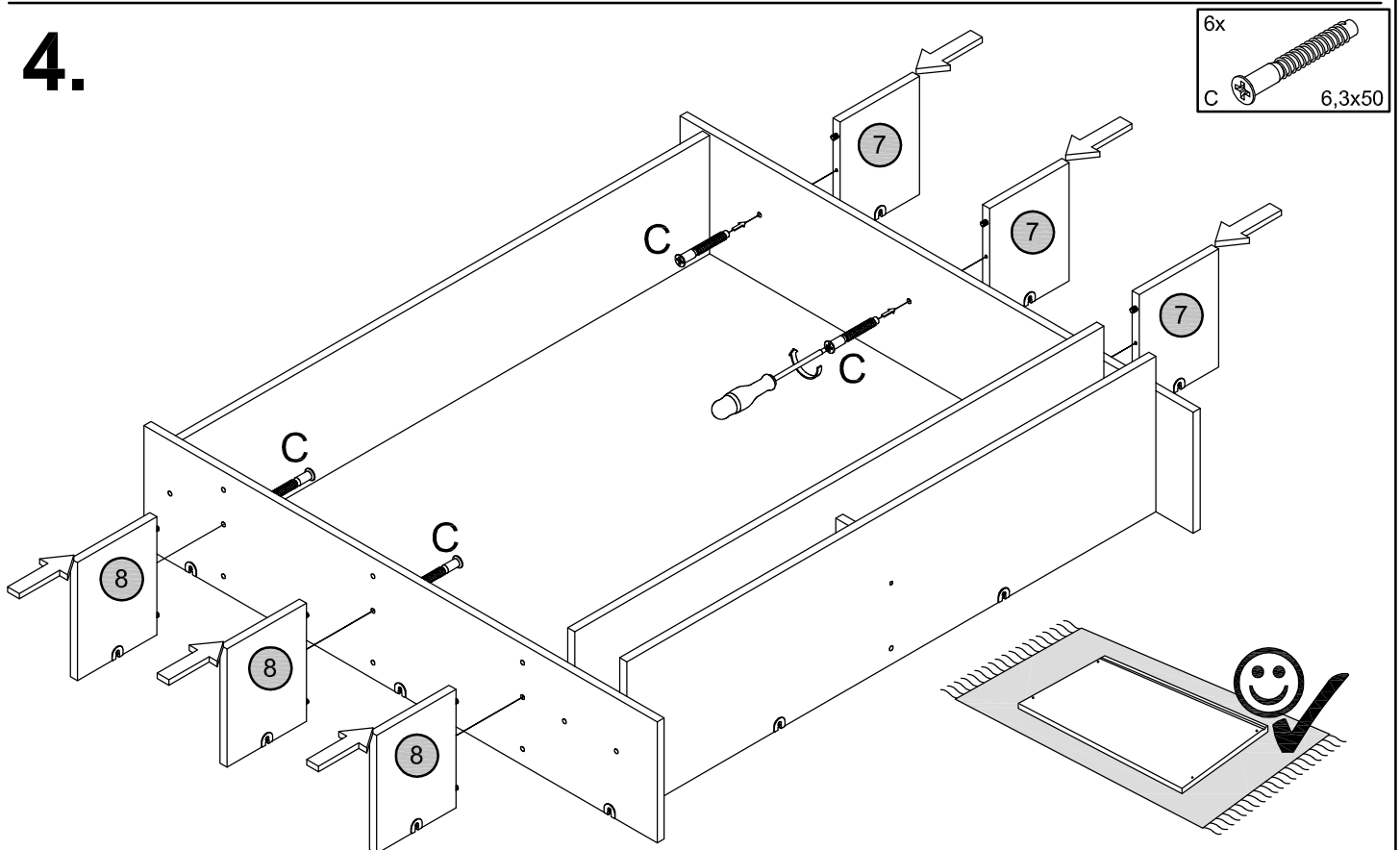

5.

- 1x M M6x60
- 1x N $\varnothing 40 \times 85$
- 12x D

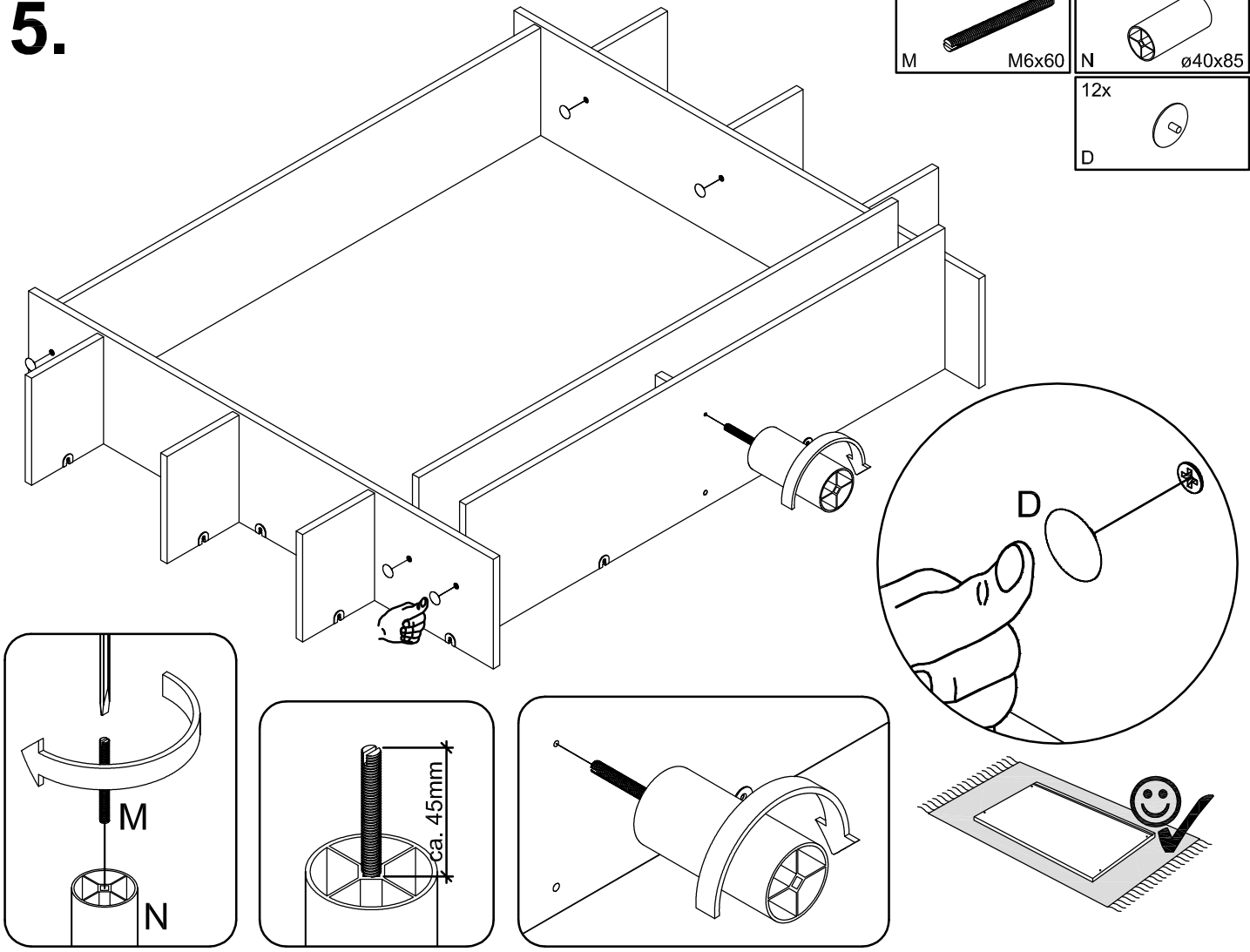

6.

- 4x B
- 8x O

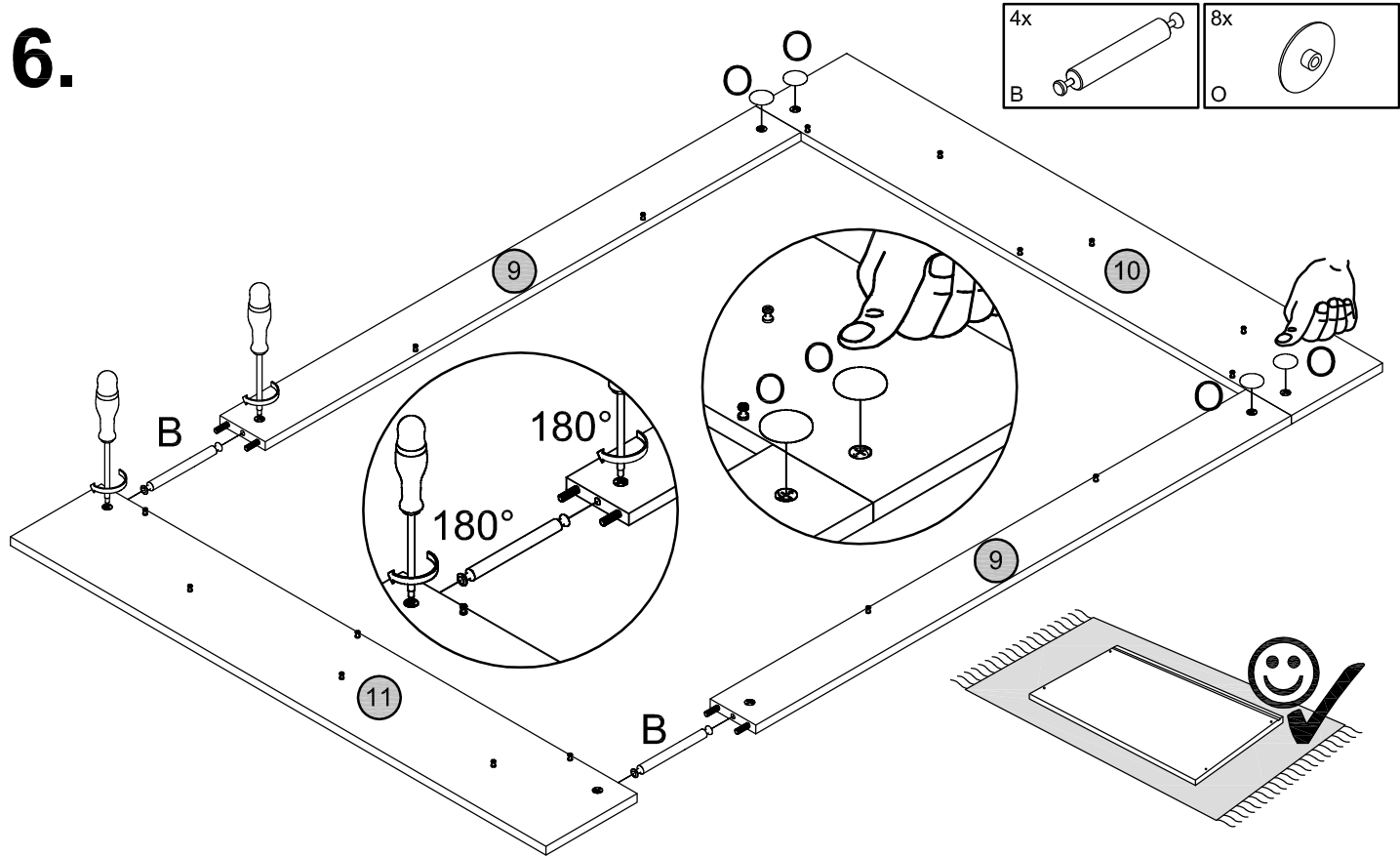

7.

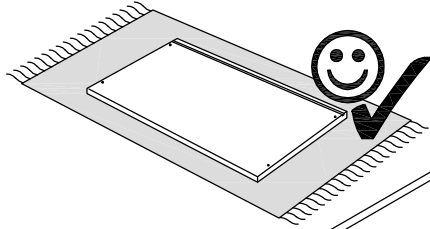

4x

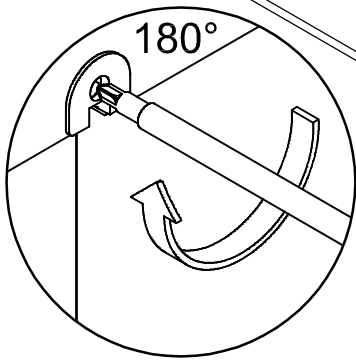

180°

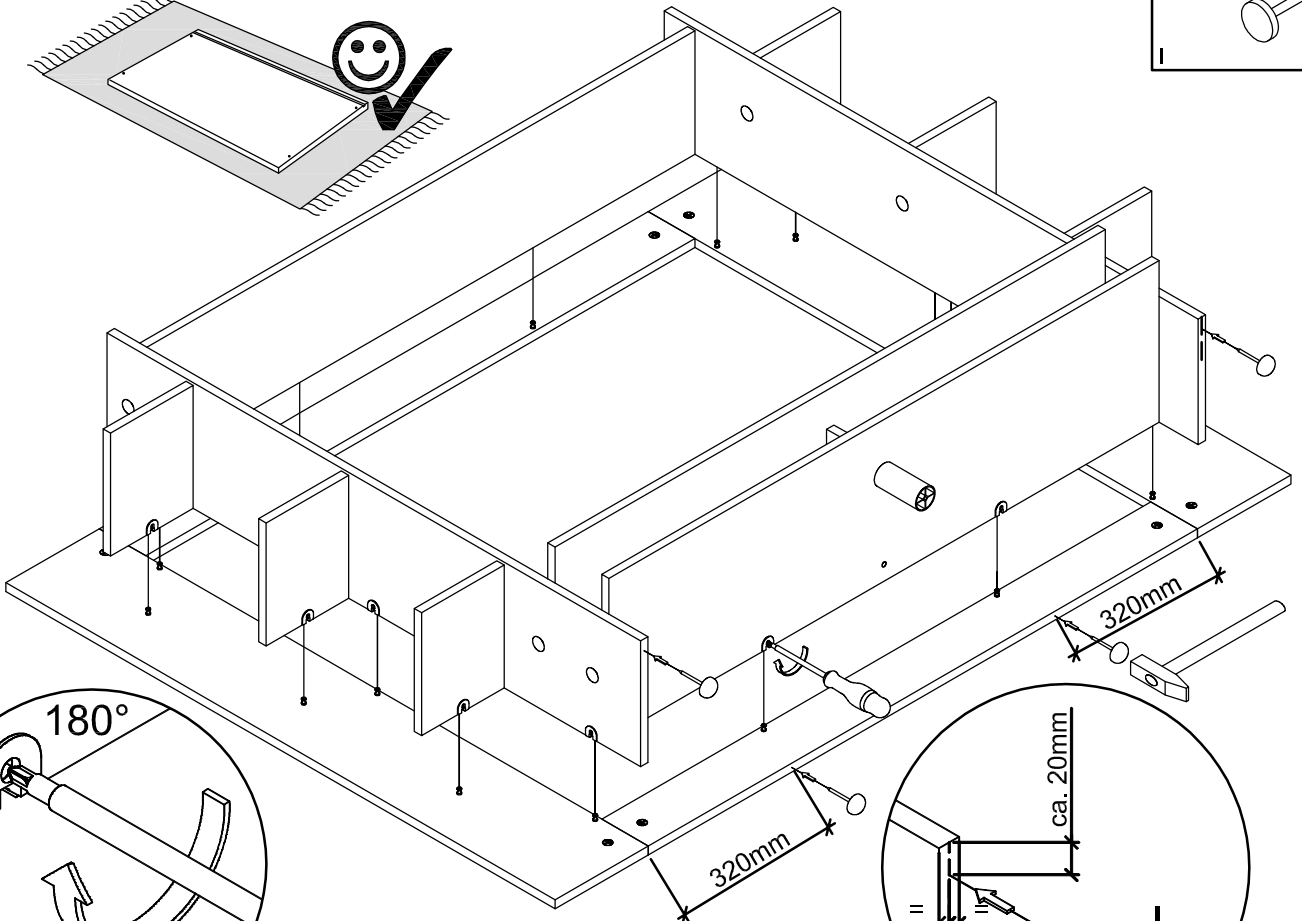

320mm

320mm

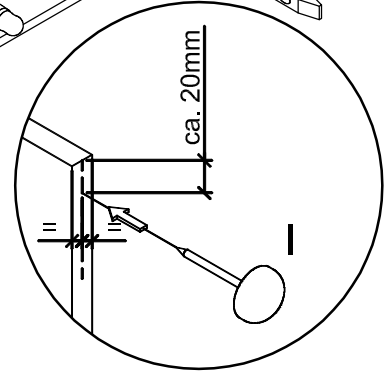

ca. 20mm

8.

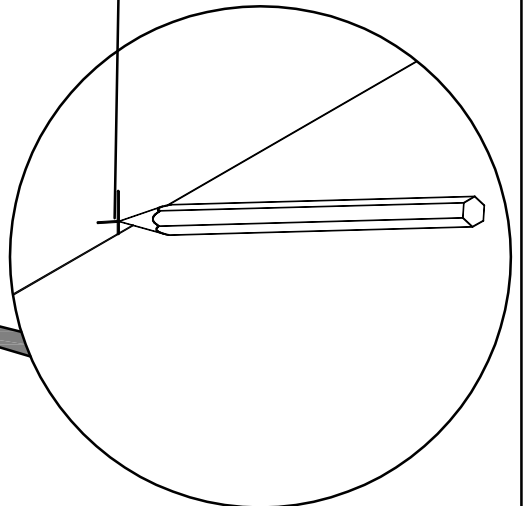
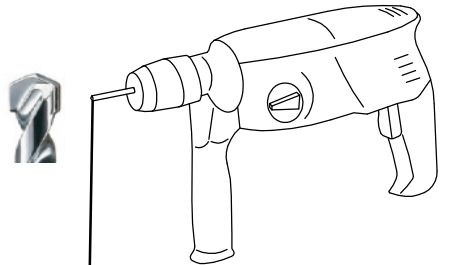
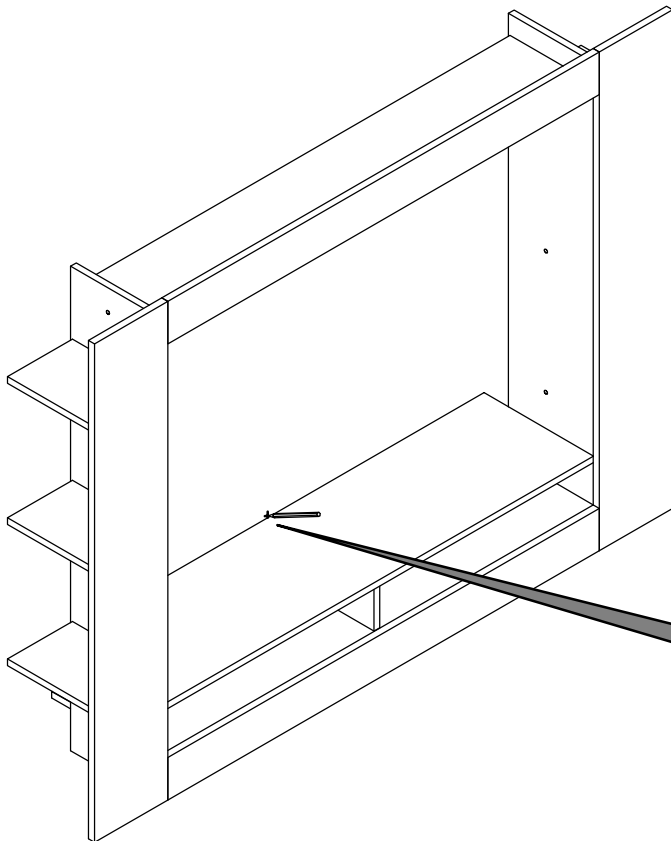

9.

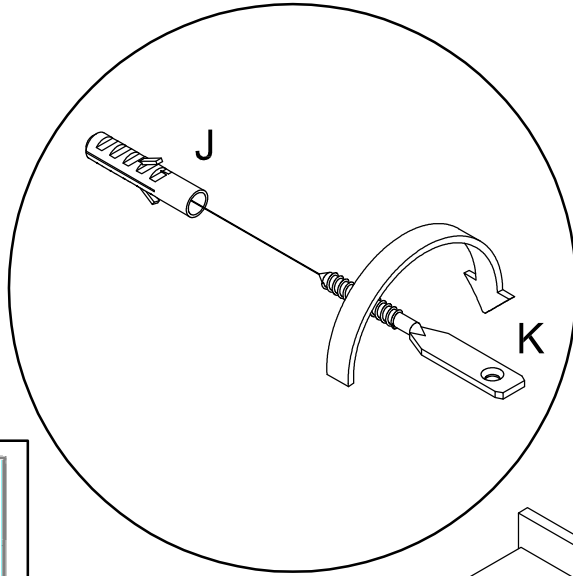

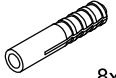
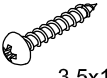
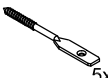
- 1x  J 8x40
- 1x  L 3,5x15
- 1x  K 5x97

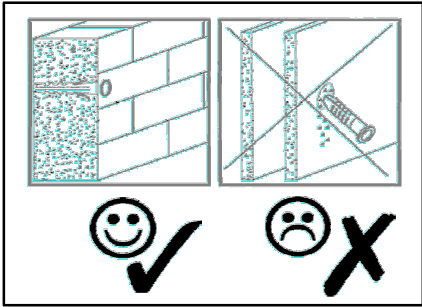

10.

