

Hergestellt für:

easyfurn GmbH

www.easyfurn.de

98547

Modellname / Model name / Nom du modèle / Modellnamn
 Nome modello / Název modelu / Modelnaam / Ime modela
 Número Modelo / Modell neve / Название модели /
 Názov modelu / Ime modela / Denumire model /
 Наименование на модела

Vancouver

Modellnummer / Number / Numéro du modèle
 Numero / Hođid nř èodílnř / modello
 Číslo modelu / Modell száma / Éíslo modelu
 Stevilka modela / Număr model

W9.410.07



- D** Bitte lesen Sie diese Montageanleitung gut durch, da wir für Fehler, die durch falsche Montage entstehen, keine Haftung übernehmen!
- GB** Please read these installation instructions through carefully as we cannot accept any liability for faults occurring as a result of incorrect installation!
- CZ** Přečtěte si prosím pozorně tento návod k montáži, aby jste předešli chybám vzniklých špatnou montáží, za které neručíme!
- F** Veuillez lire attentivement cette notice de montage, car nous déclinons toute responsabilité en cas d'erreurs découlant d'un montage erroné !
- I** Prego leggere attentamente le istruzioni per il montaggio, poiché decliniamo qualsiasi responsabilità per difetti derivanti da un montaggio errato
- BG** Ёол, ддоочлнлнл внщєтлнлно ёонлїтєнчлн чнлїлїдуєцщ, лїлї ёлїло нл нолїщє олїлїоводнолїл зл ўлїлїщ, влїлїщєнлїлї в лїлїлїлїлїлї нл длодлїлїлї ёонлїтє.
- NL** Leest u alstublieft deze montagehandleiding goed door, voor fouten door verkeerde montage zijn wij niet verantwoordelijk.
- PL** Proszę uważnie zapoznać się z instrukcją montażu, ponieważ nie ponosimy odpowiedzialności za niewłaściwy montaż.
- HR** Molimo vas da pažljivo prcitate uputstva za satavljanje, jer ne snosimo odgovornost za pogreske nastale zbog ne odgovarajućeg sastavljanja.
- HU** Kérjük, olvassa el figyelmesen ezt az összeszerelési útmutatót, mert a helytelen összeszerelésből a dódó hibákért nem vállalunk felelősséget!
- SK** Prosíme, dobre prečítajte si tento návod na montáž, pretože nepreberáme žiadne ručenie za chyby, ktoré vzniknú na základe chýbnej montáže!
- SLO** Preberite ta navodila za montažo, ker mi ne prevzemamo odgovornosti za napake, ki nastanejo kot posledica napacne montaže!
- RO** Vă rugăm să citiți cu atenție aceste instrucțiuni de montaj deoarece nu preluăm garanția pentru defecte ce apar datorită unui montaj incorect!
- RUS** Пожалуйста, внимательно ознакомьтесь с данной инструкцией по монтажу, поскольку мы не несем ответственности за ошибки, причиной которых является неправильный монтаж.
- S** Läs noggrant igenom dessa monteringsanvisningar. Vi övertar inget ansvar för felaktigt montering!!

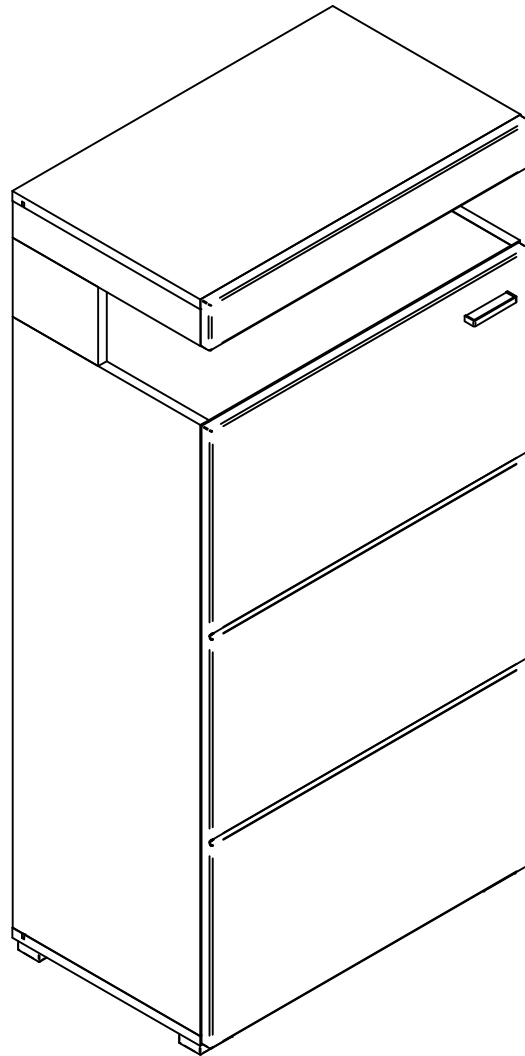

max. zulässige Belastungen von Einlegeböden in Kg:

Länge	Stärke			Massivholz			Spanplatte			Glas	RW
	mm	15	18	20	15	18	22	5 / 6 / 8	mit Boden		
0 ≤ 400								Länge bis 600mm / 10kg	Länge 1000mm		
401 ≤ 600	20	20	20	15	15	15		Länge bis 900mm / 5kg	max.5kg%		
601 ≤ 800				10							
801 ≤ 1000	10			5	5						

25.03.2014

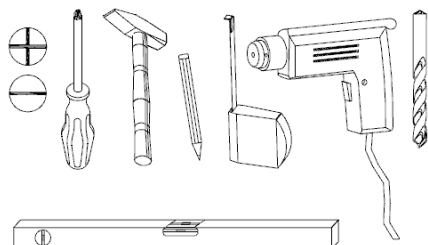

festziehen / tighten / Затягивать /
 serrer / stringere utåhnut / vasttrekken /
 zategnuti/strângere / zwiázac /
 szorosan meghúzni / revne dotiahnut /
 trdno pritegniti / затянуть / dra át



eindrücken / press in / enfoncer /
 ribattere / zatlačit / Вкарайте /
 Benyomni / silacit' / vtisniti / tryck in
 introducere prin apasare / вдавить



ausmessen / measure / mesures /
 misurare / opmeten / izmeriti / miara /
 kímérni / izmeriti / masurare / измерить
 změřit / Измерете / mät upp



drücken / press / presser / stisknout /
 HaTNCHeTe /vtisniti / nasinac / drukken /
 pritisnuti / nacisnac / pritisniti / нажать /
 zarazit / Забийте (с чук) / zabiti /
 (Meg)nyomni / apasare / tryck fast



einschlagen / hammer in / bevern / sla in
 frapper au marteler / infossare / Zabit' /
 zarazit / Забийте (с чук) / zabiti /
 Introducere prin bătăie / забить







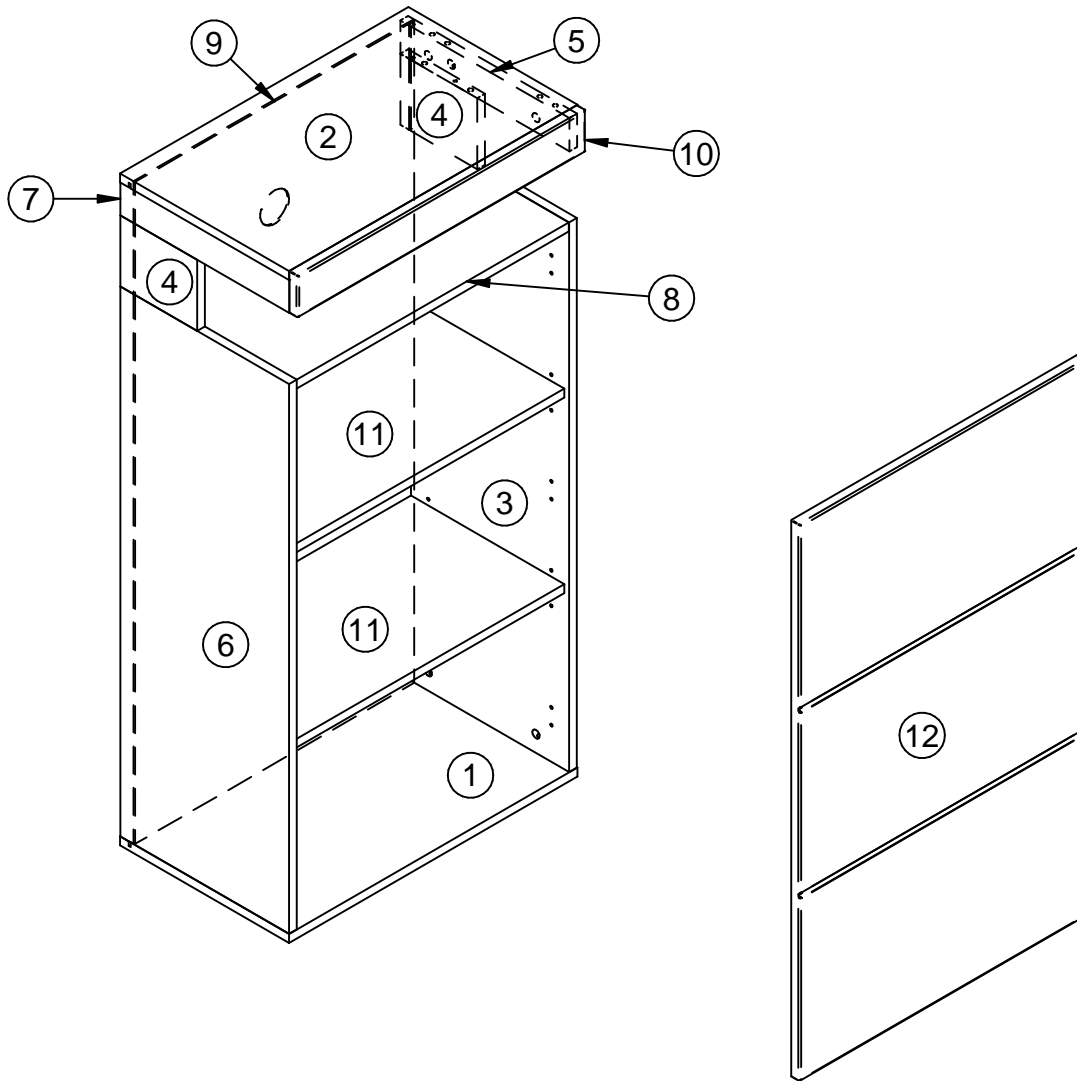







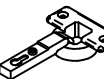

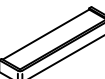

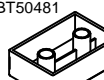
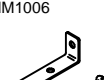
Drehen - wenden / Proszę odwrócić /
 Keren - omdraaien / Girare - Ruotare /
 Okrenuti - ubrnuti / Retourner - renverser /
 Turn over - turn around / Otocte - obratite /
 Обърнете - завъртете / Obrnite list /
 Întoarceți / rotiti / Vrid runt - vänd /
 прокрутить - повернуть



Bauteile Type: W9.410.07

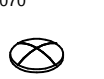
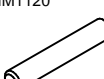

Beschlagteile Type: W9.410.07

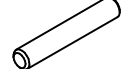

BT1005.xx  x8	BT1016  x16	BT50103  x4	BT1304  x3	BT1305  x3	BT50162.xxx  x2	BT50210  x1	BT50244.xxx  x16
BT50253.xxx  43x20x20 x2	BT50481  60x40x20 x4	MM1006  x1	MM1010  M4x27 x2	MM1016  11mm Silbergrau x16	MM1018  x3		
MM50294  Ø4x20 x8	MM1046  Ø3,5x13 x14	MM1048  Ø2,7x20 x2	MM1070  Ø7x1,5 x2	MM1120  Ø8x50 x8	MM1121  Ø8x30 x12		

1.

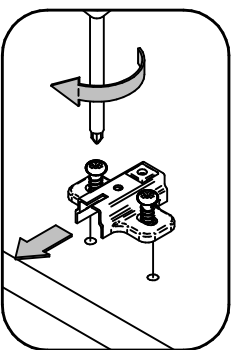
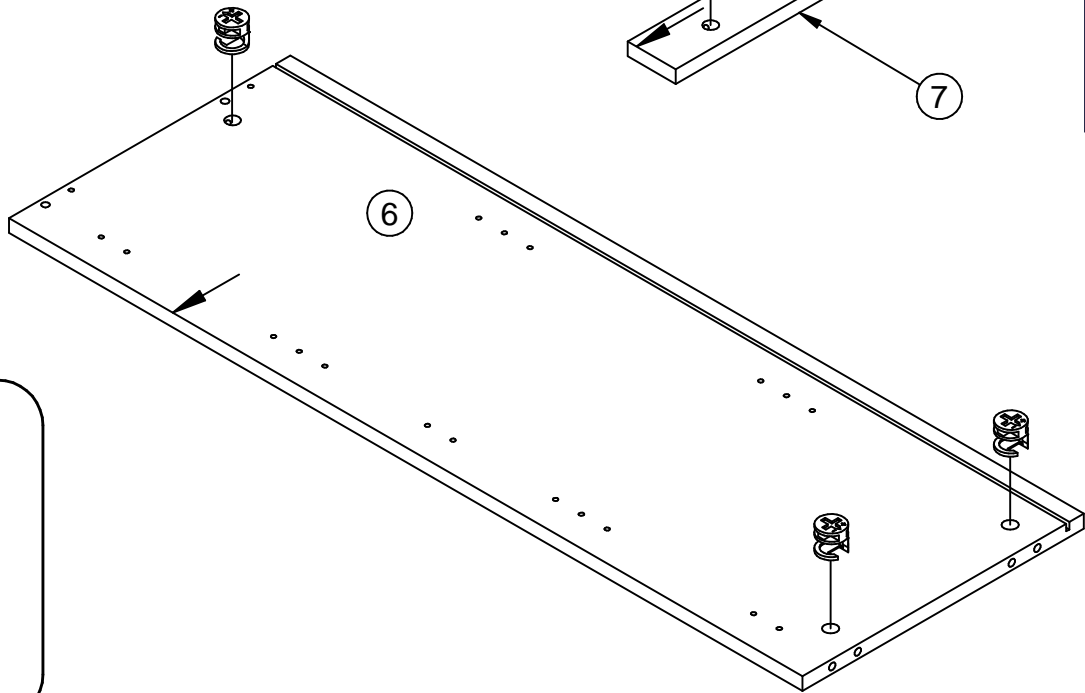
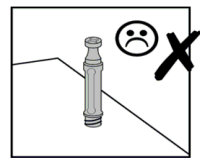
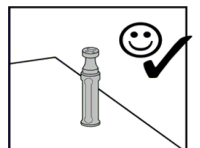
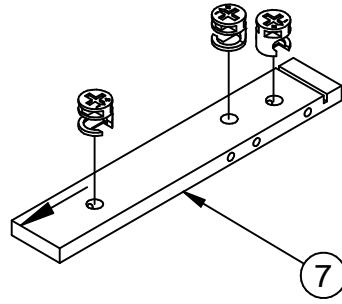
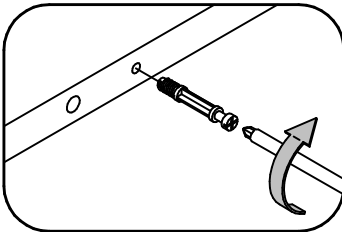
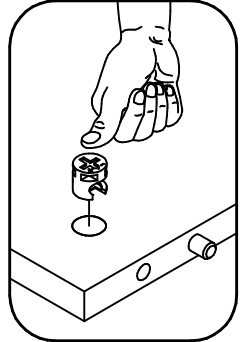
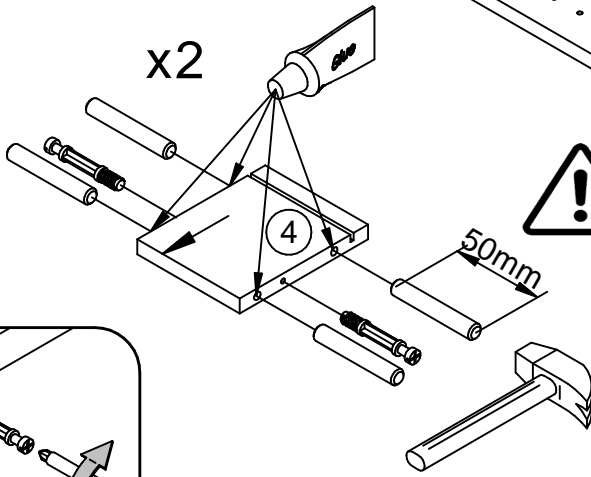
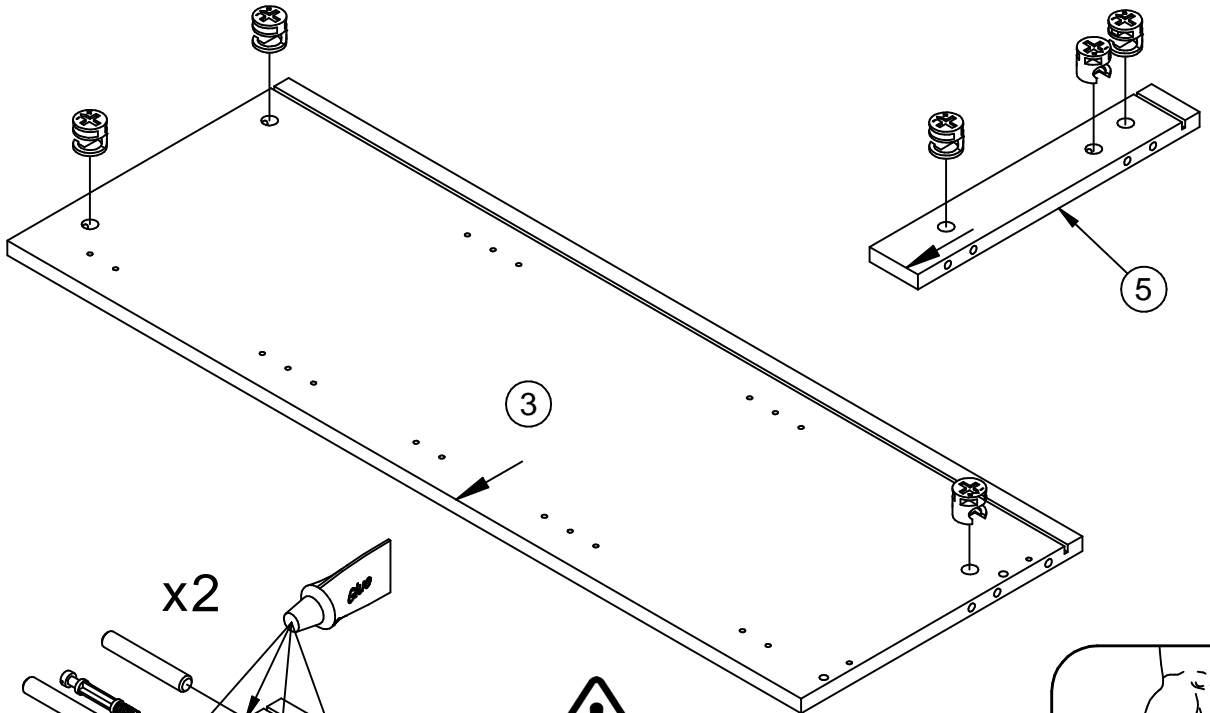
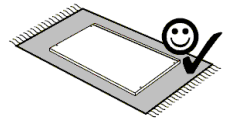
BT1016 	MM1016  1mm Silbergrau	MM1018 	MM1120  Ø8x50
x12	x4	x1	x8



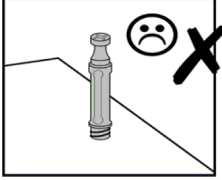
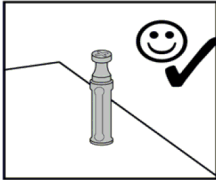
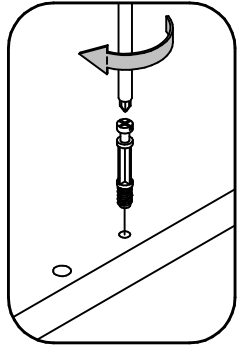
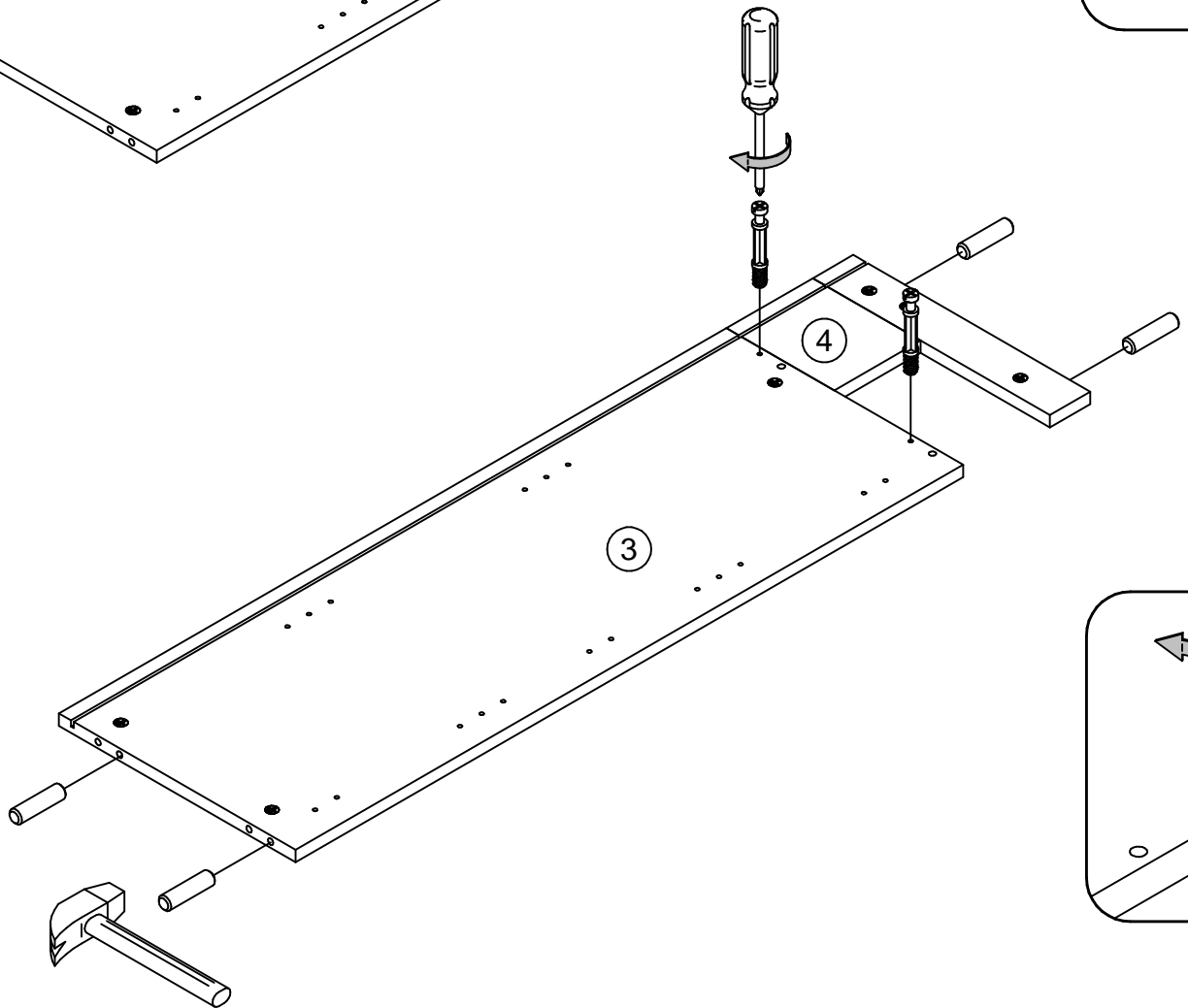
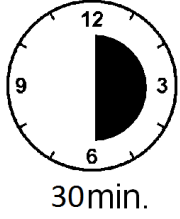
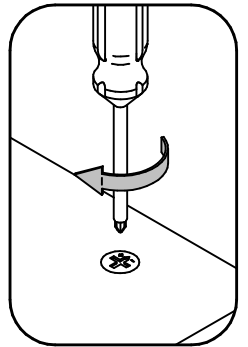
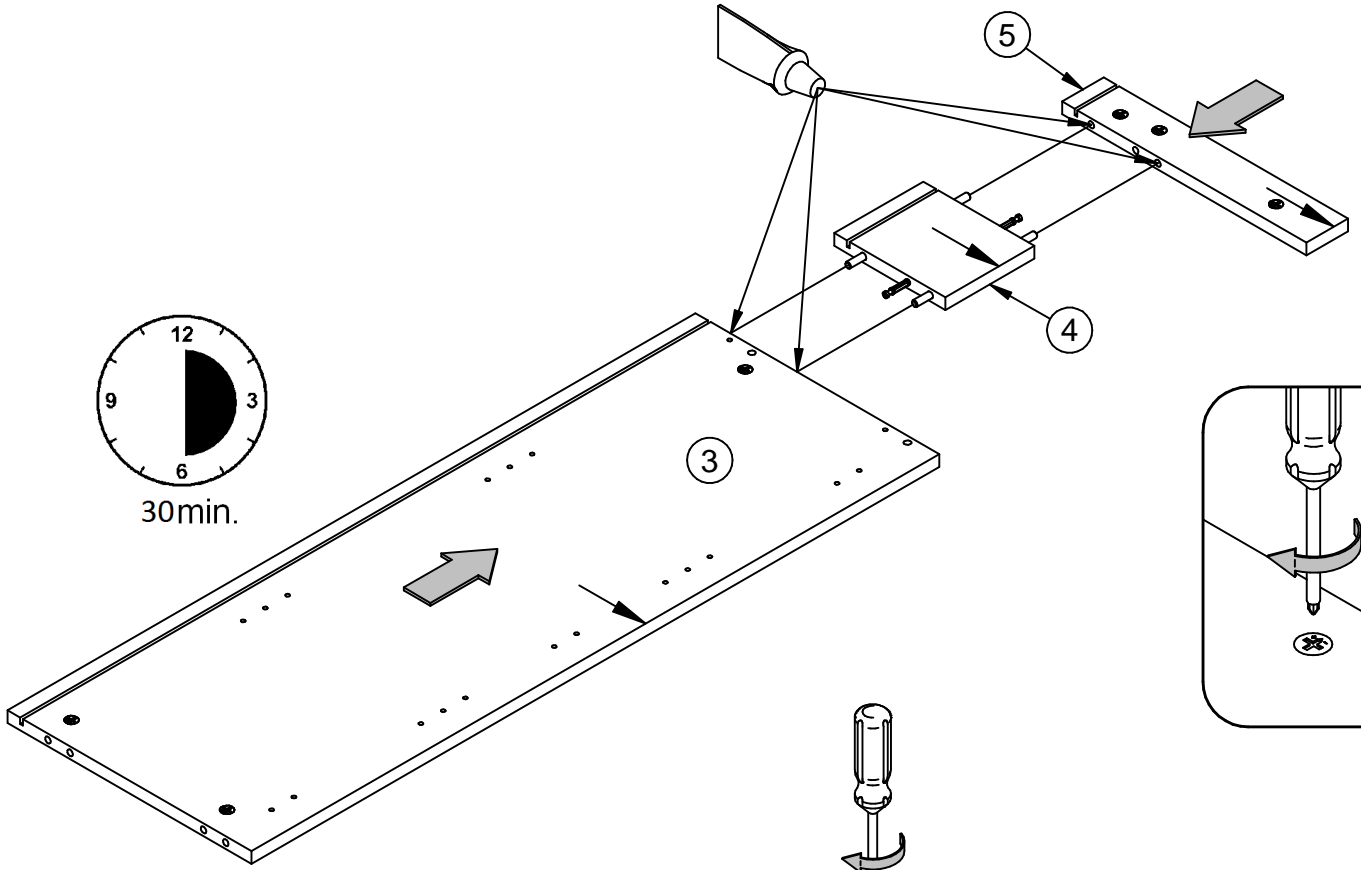
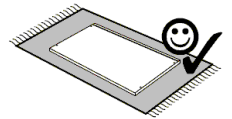

2.

MM1016  Silbergrau x2	MM1018  x1	MM1121  Ø8x30 x4
-----------------------------------------------------------------------------------------------------------------	---------------------------------------------------------------------------------------------------	------------------------------------------------------------------------------------------------------------



3.

MM1016  Silbergrau x2	MM1018  x1	MM1121  Ø8x30 x4
-----------------------------------------------------------------------------------------------------------------	---------------------------------------------------------------------------------------------------	------------------------------------------------------------------------------------------------------------

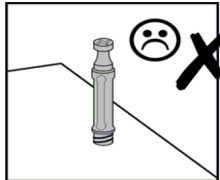
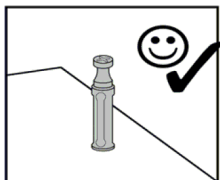
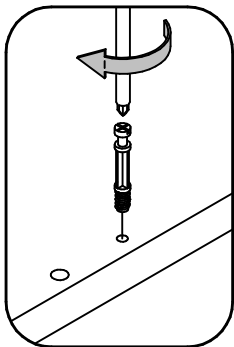
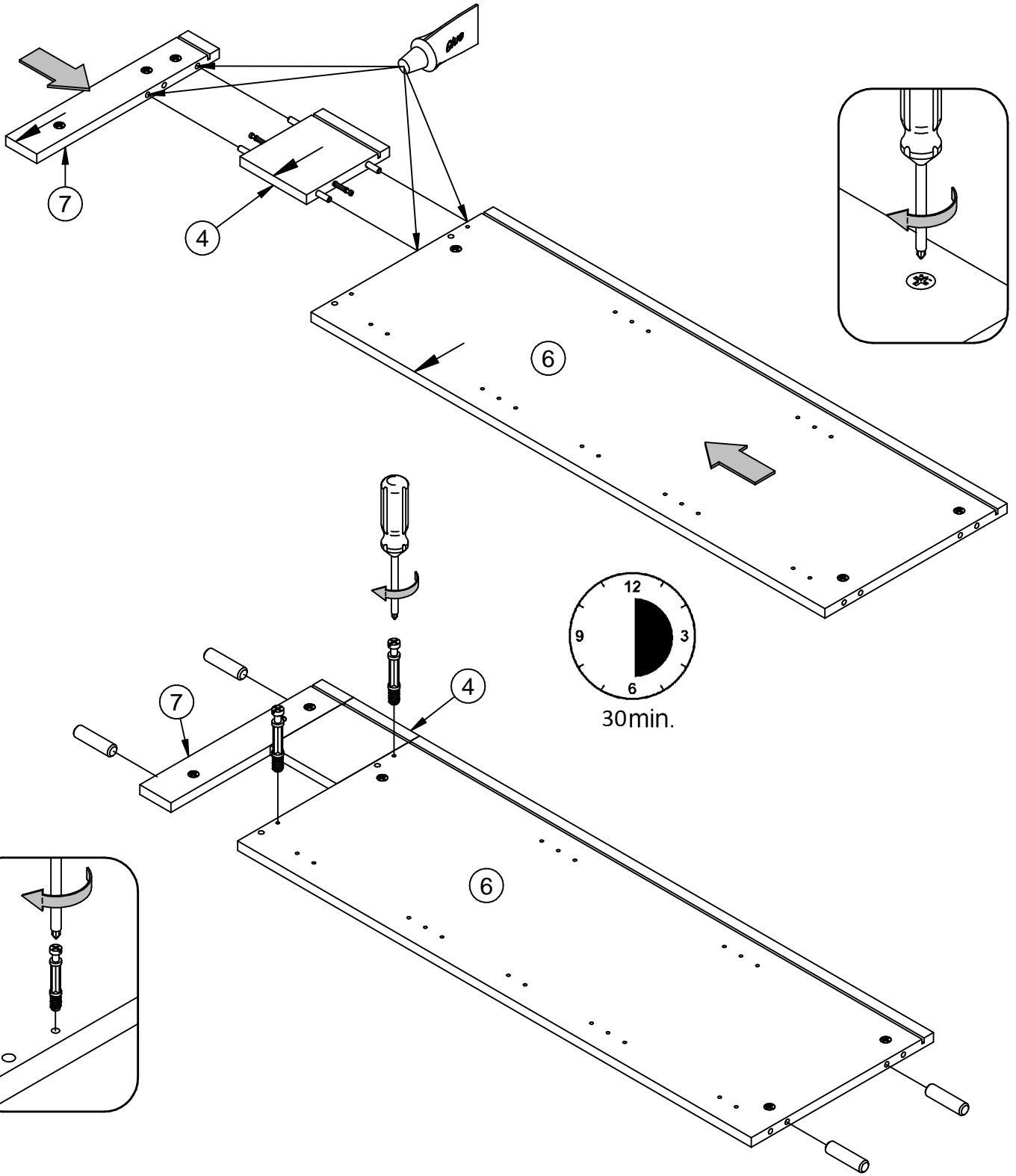
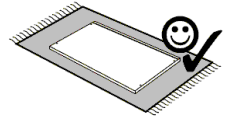

4.

BT50253.xxx 43x20x20 x2	MM1046 Ø3.5x13 x4	BT1016 x4	MM1121 Ø8x30 x4	MM1016 1mm Silbergrau x8
-------------------------------	-------------------------	--------------	-----------------------	-----------------------------------

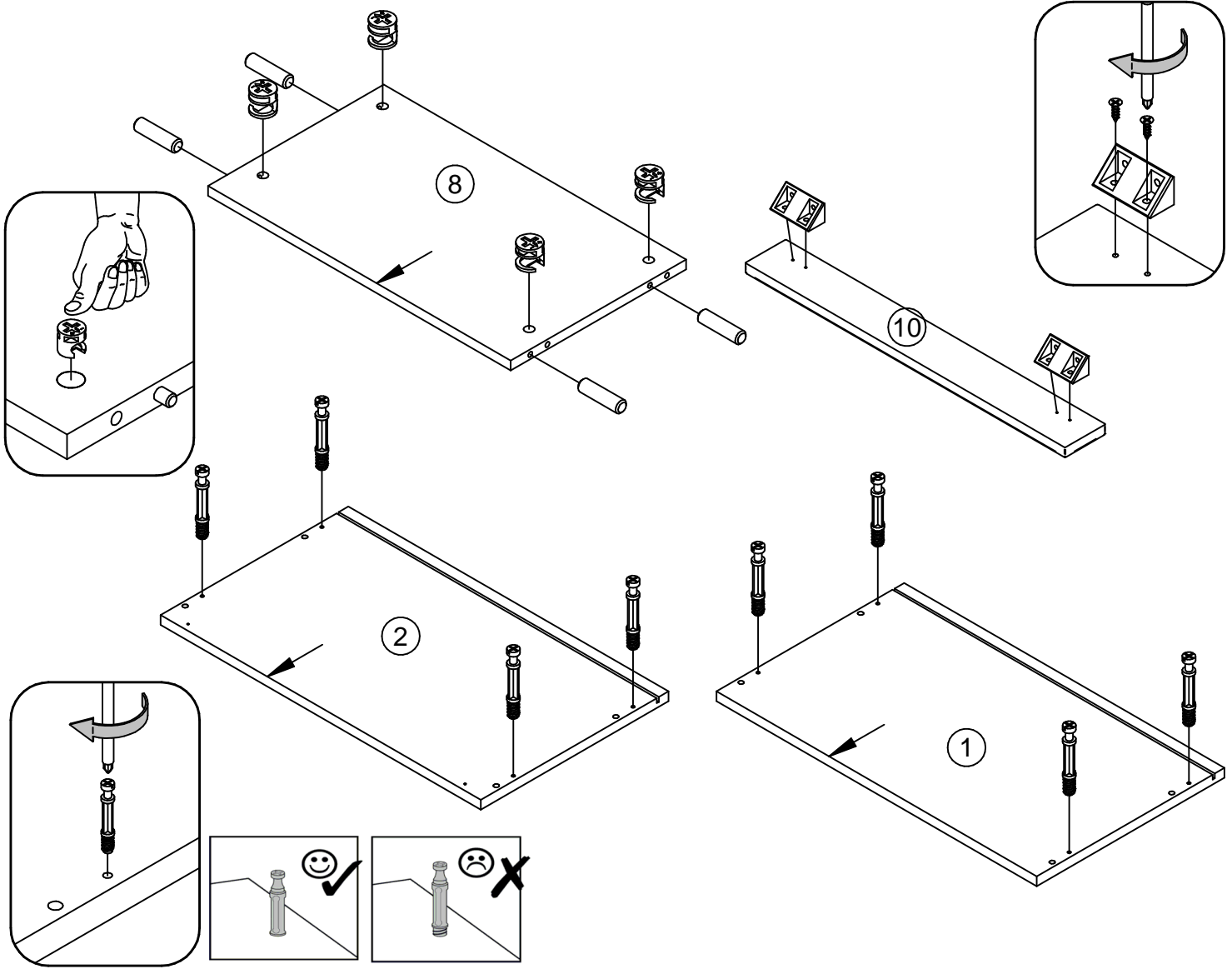
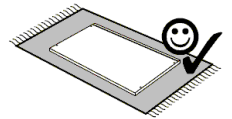

5.

MM1046 Ø3.5x13 x4

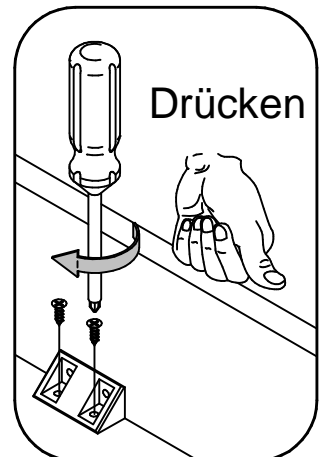
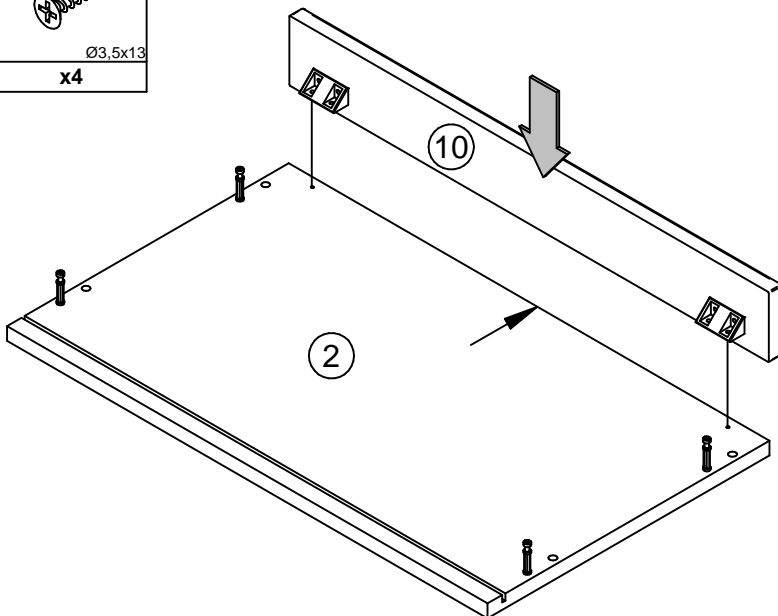
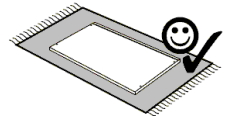

6.

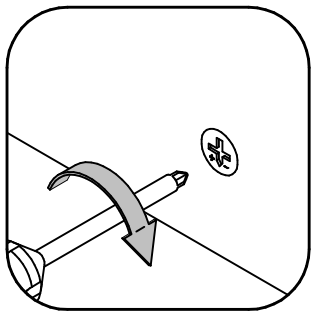
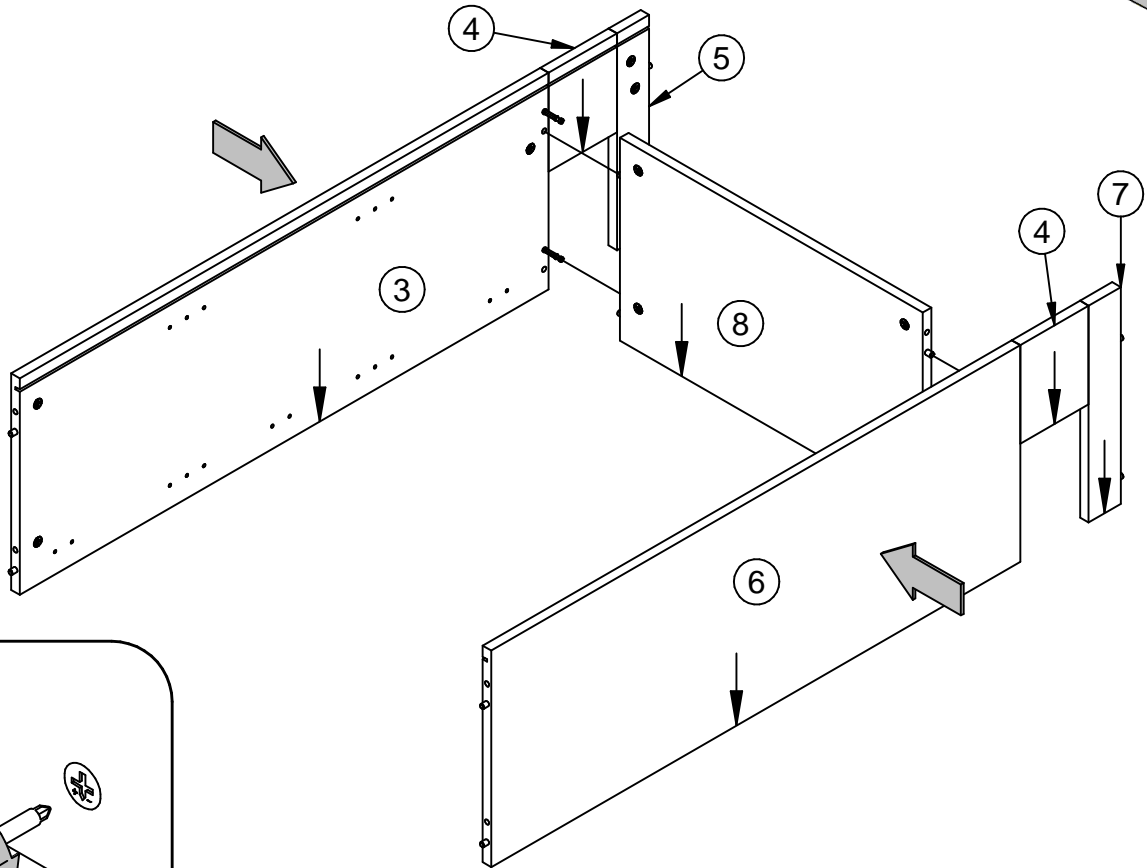
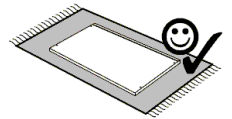

7.

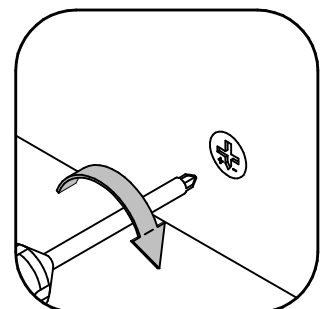
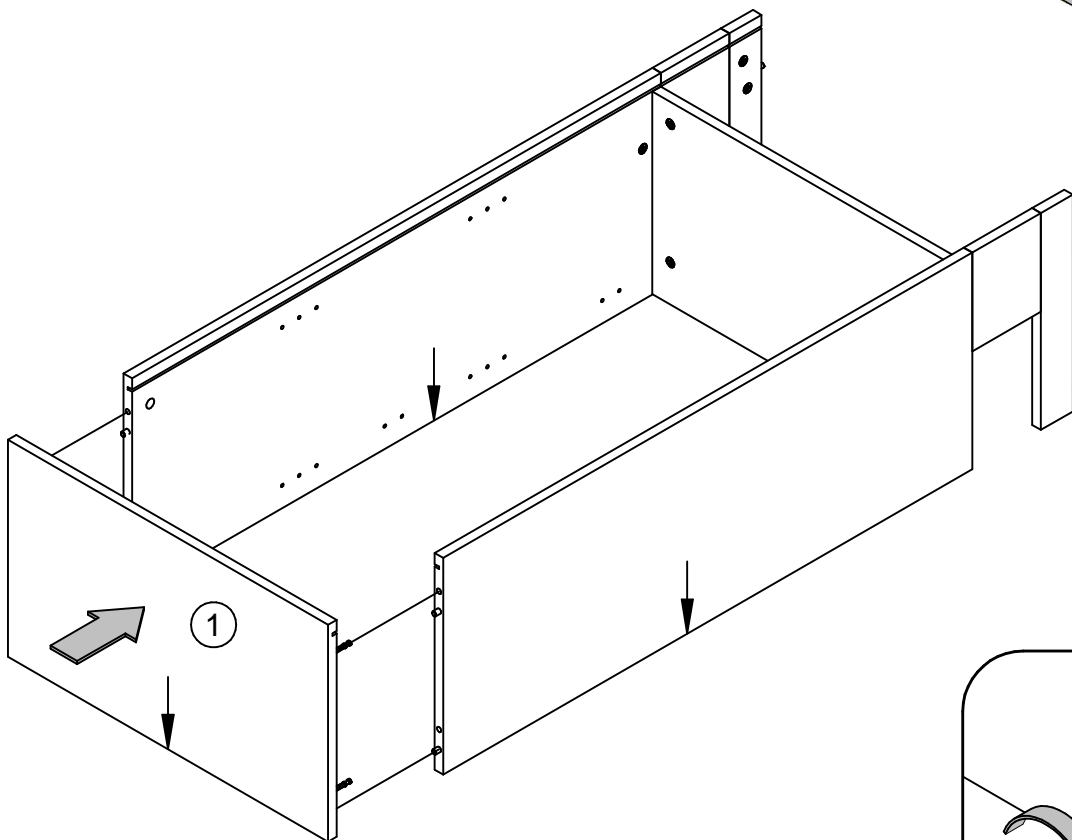
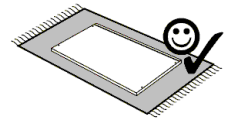

8.

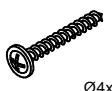
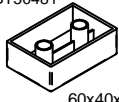

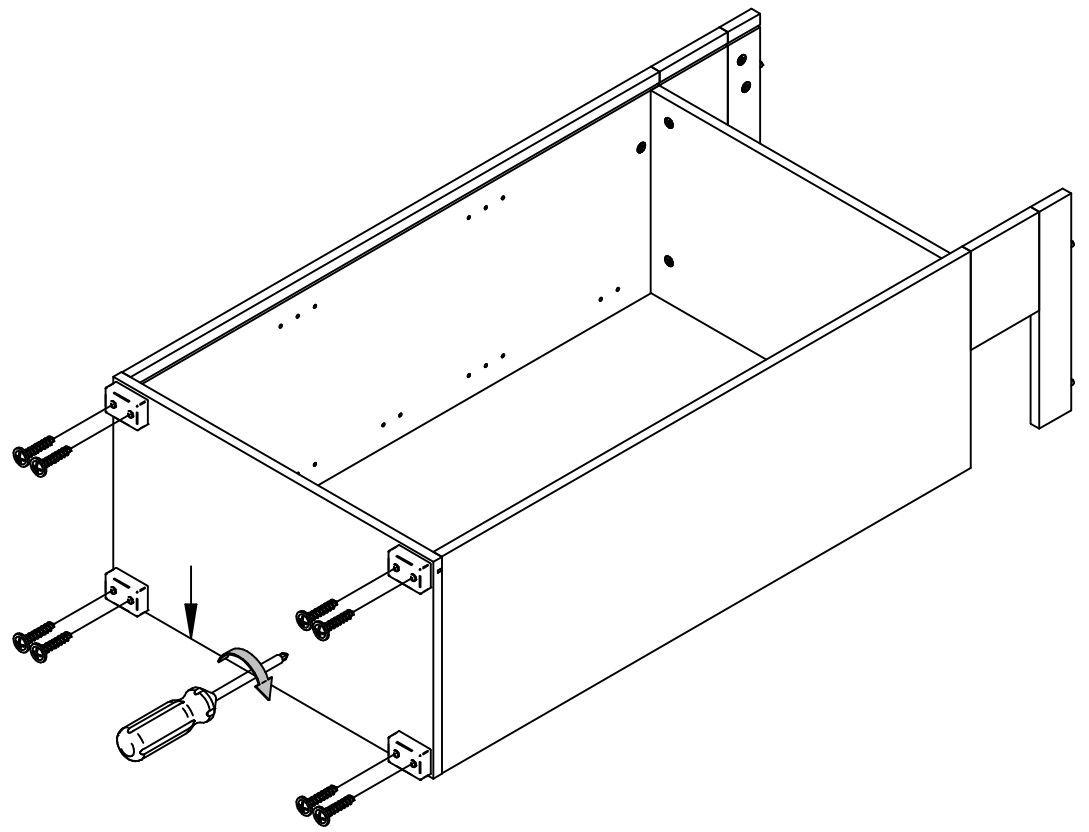
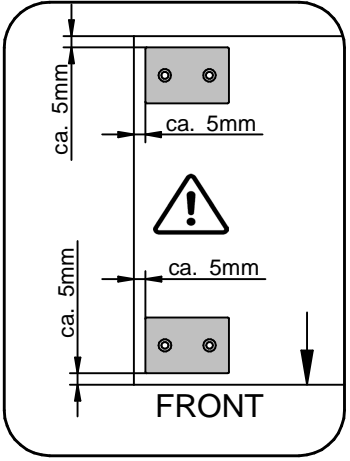
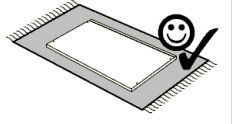
MM50294	BT50481
	
Ø4x20	60x40x20
x8	x4

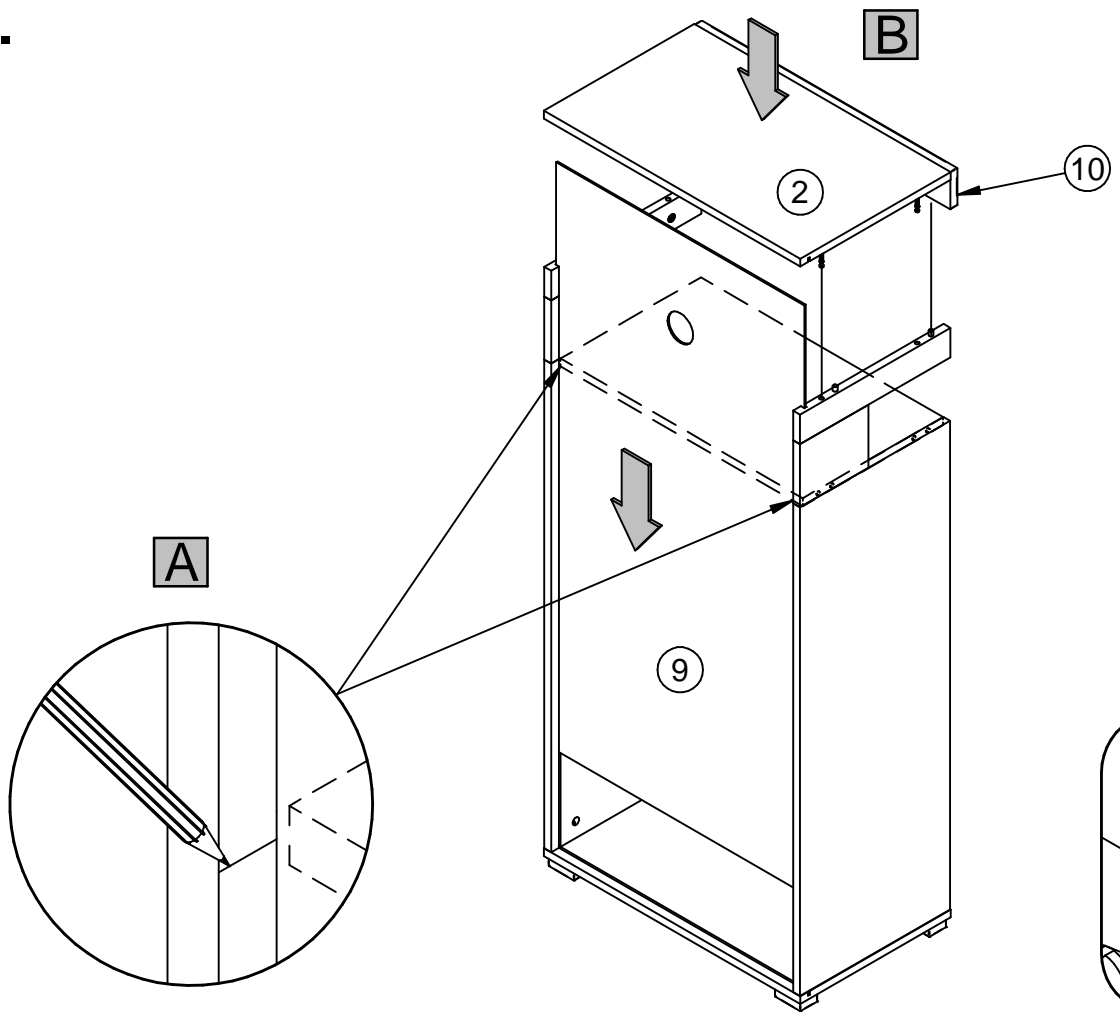

9.



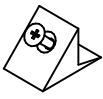

10.

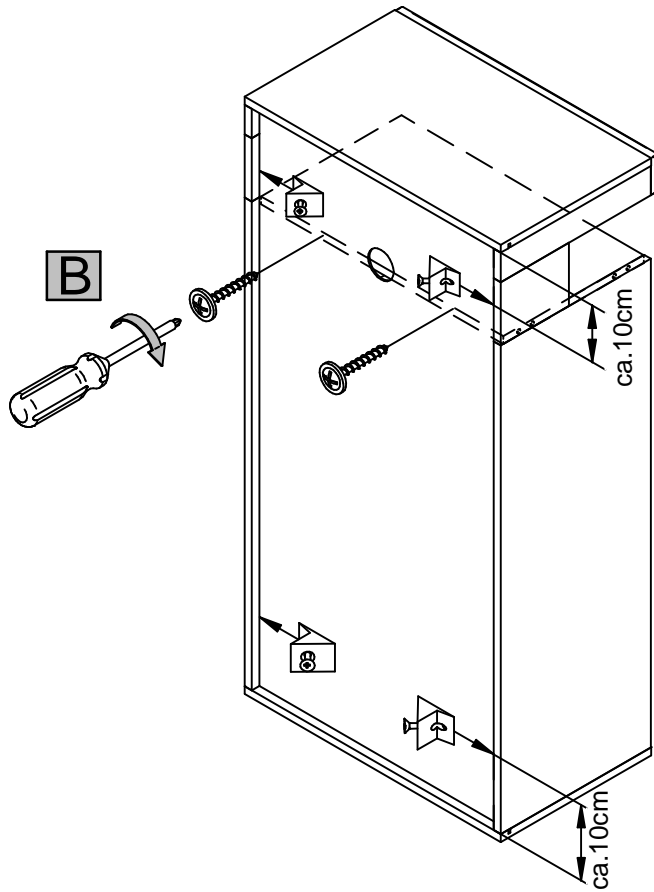
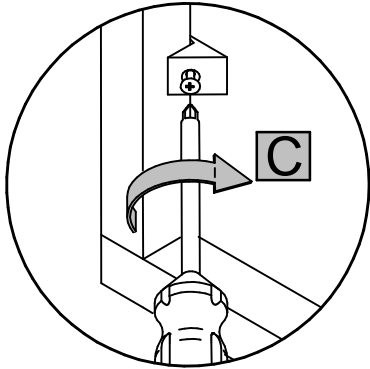
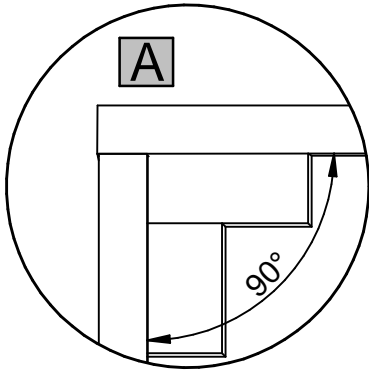
BT50103	MM1048
	
x4	x2

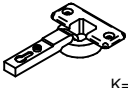

11.

MM1046	BT1305	MM1070
		
Ø3,5x13	K=0	Ø7x1,5
x6	x3	x2

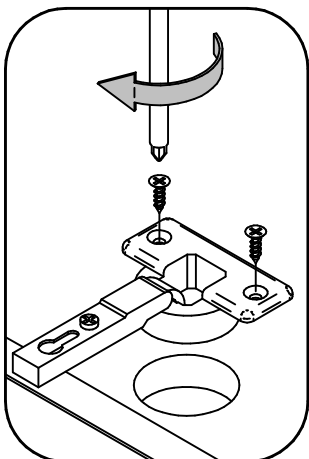
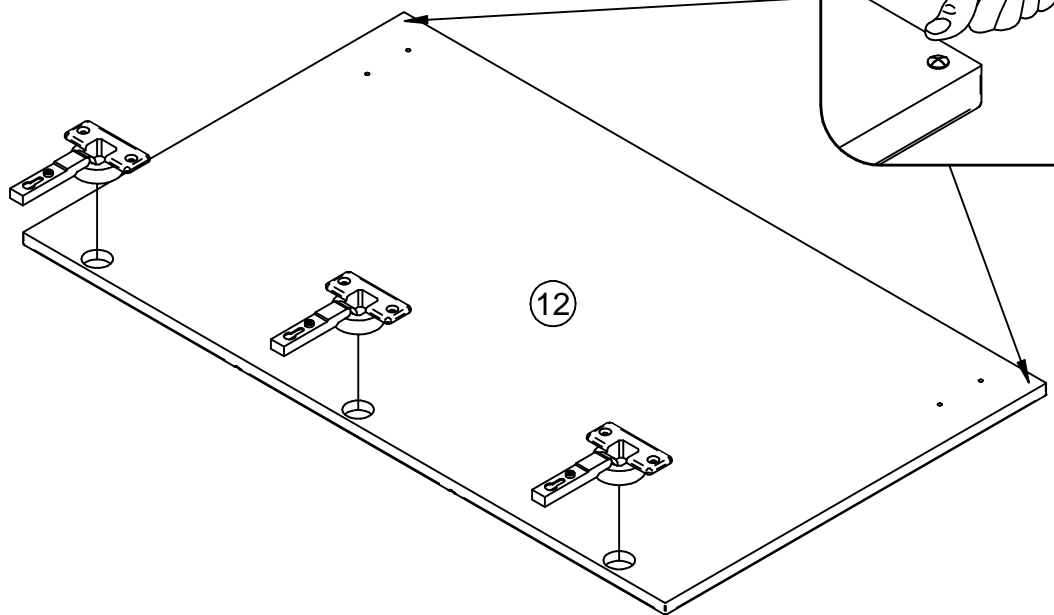
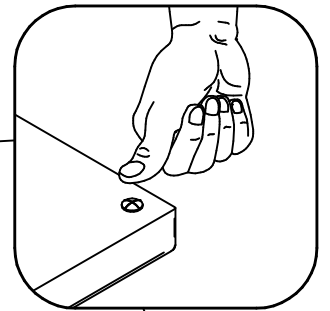
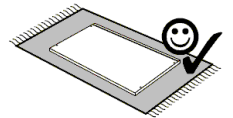

12.

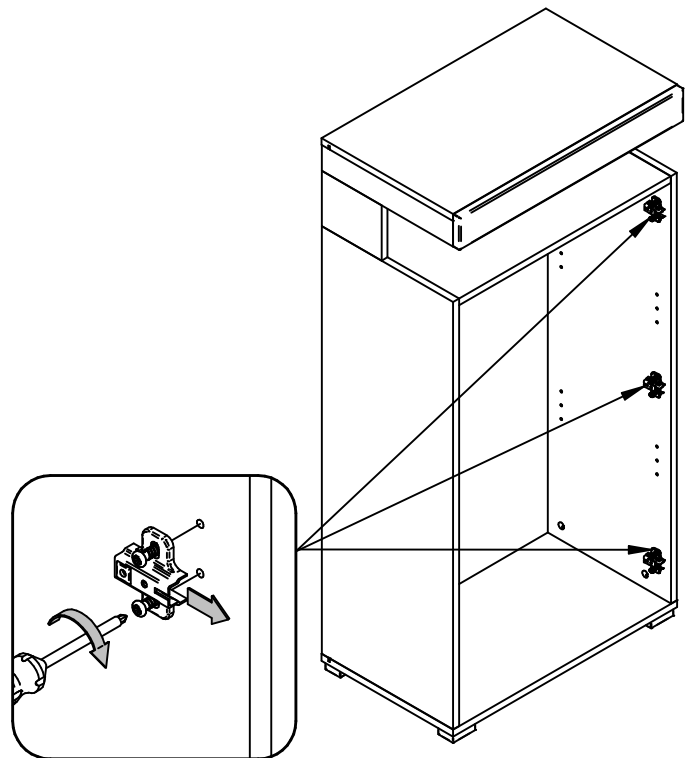
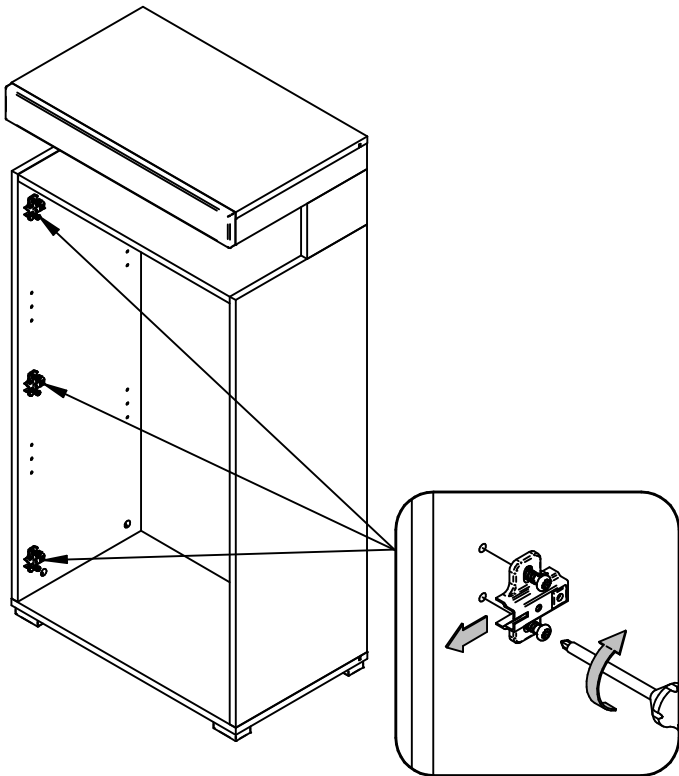
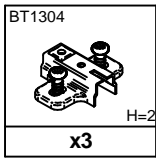

13.

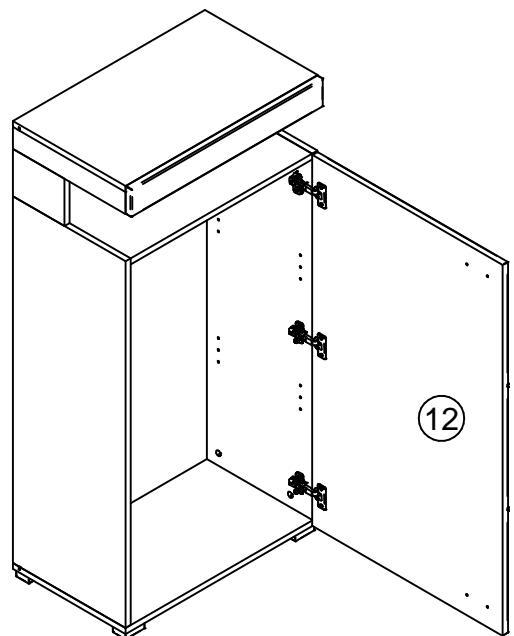
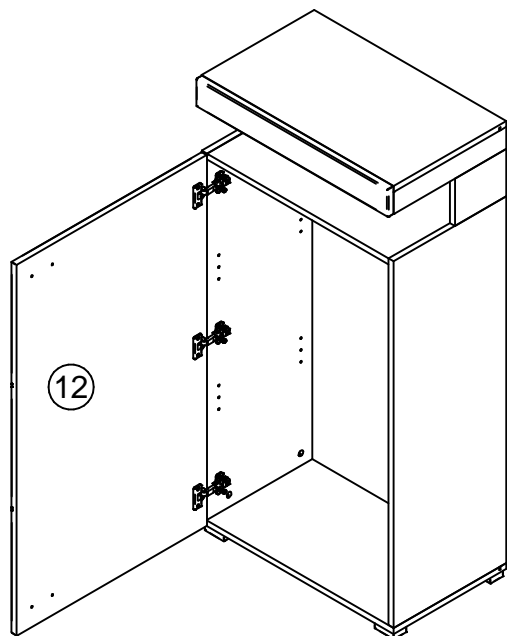
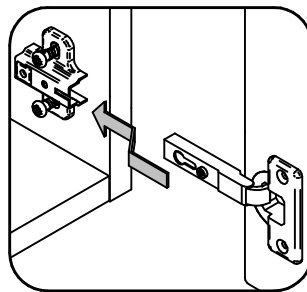
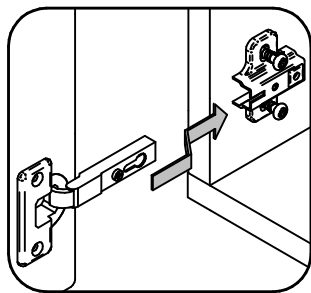

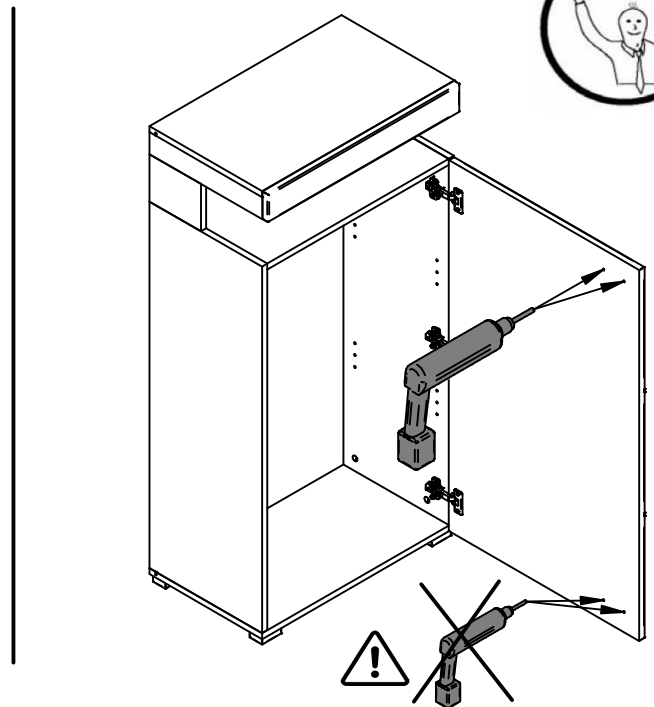
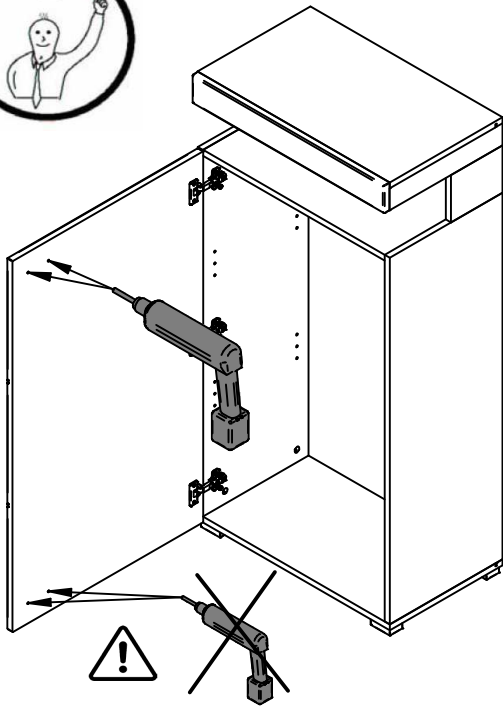
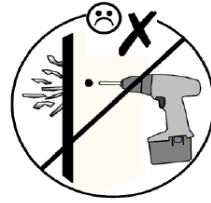
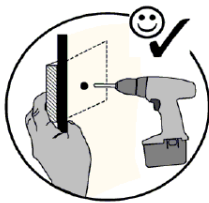
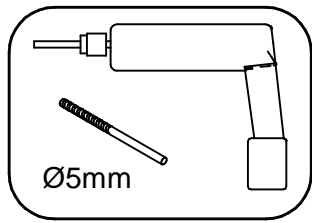

14.

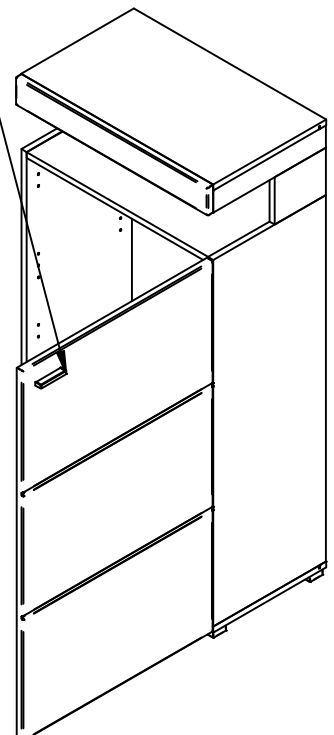
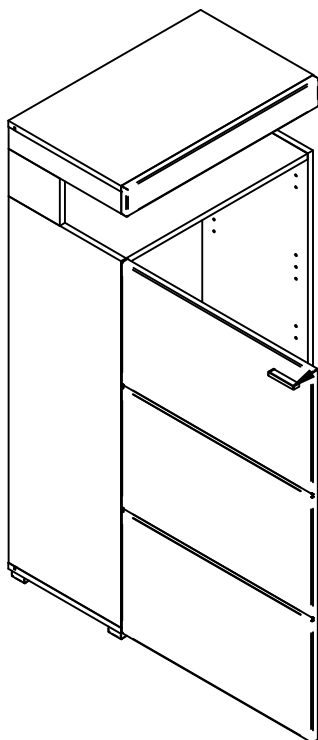
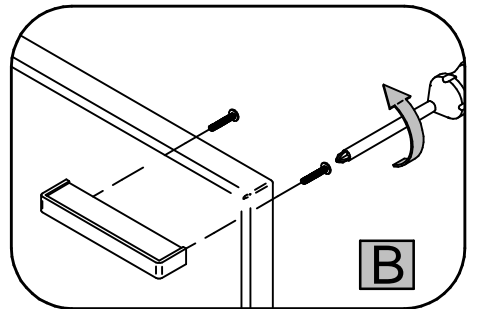
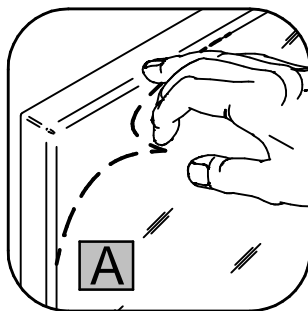
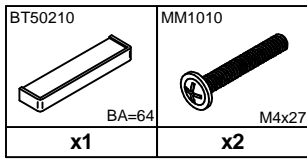

15.

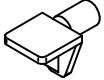

14.

BT1005.xx  x8	BT50162.xxx  x2 Ø5	BT50244.xxx  x16 Ø20
------------------------------------------------------------------------------------------------------	--------------------------------------------------------------------------------------------------------------	----------------------------------------------------------------------------------------------------------------

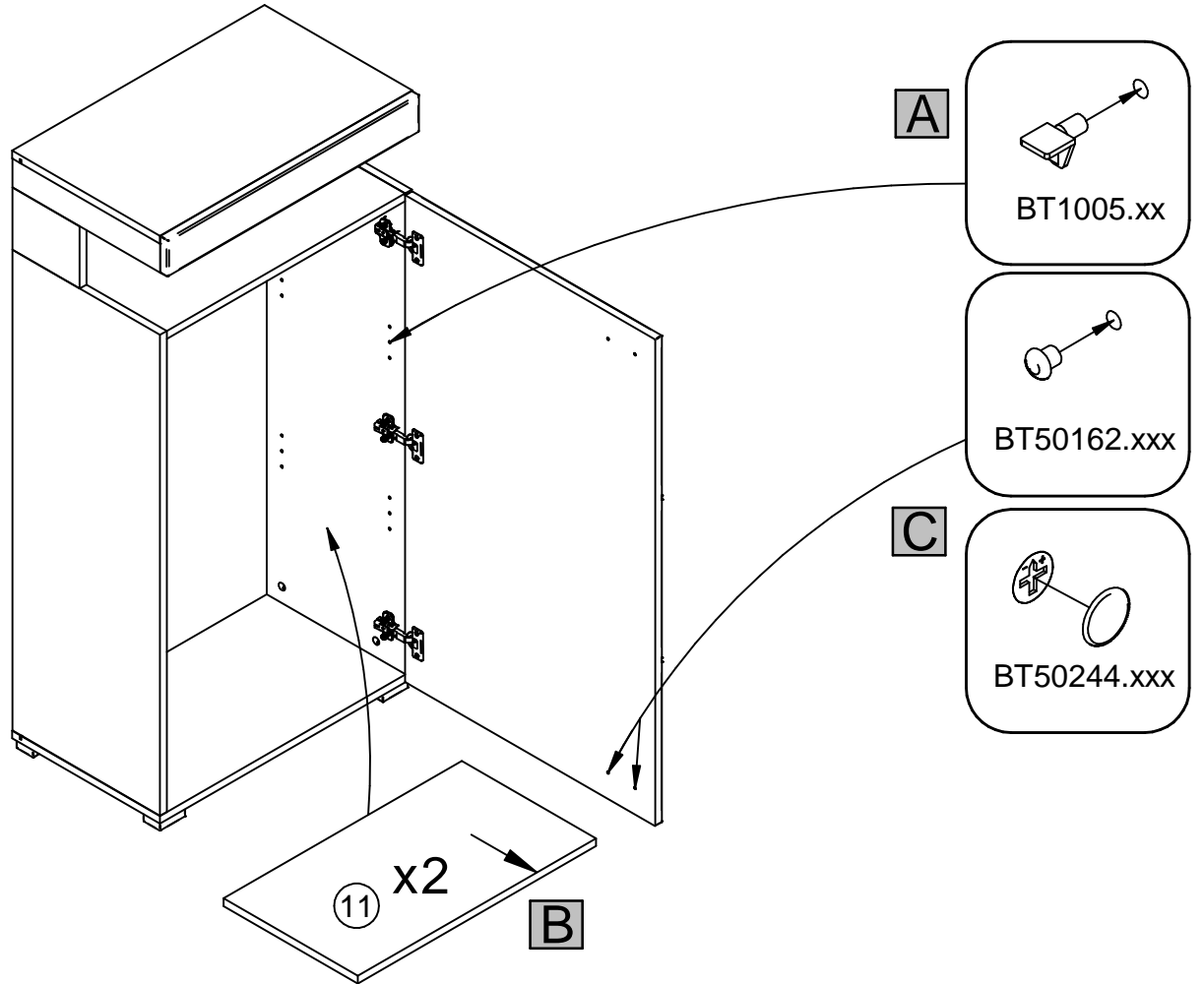
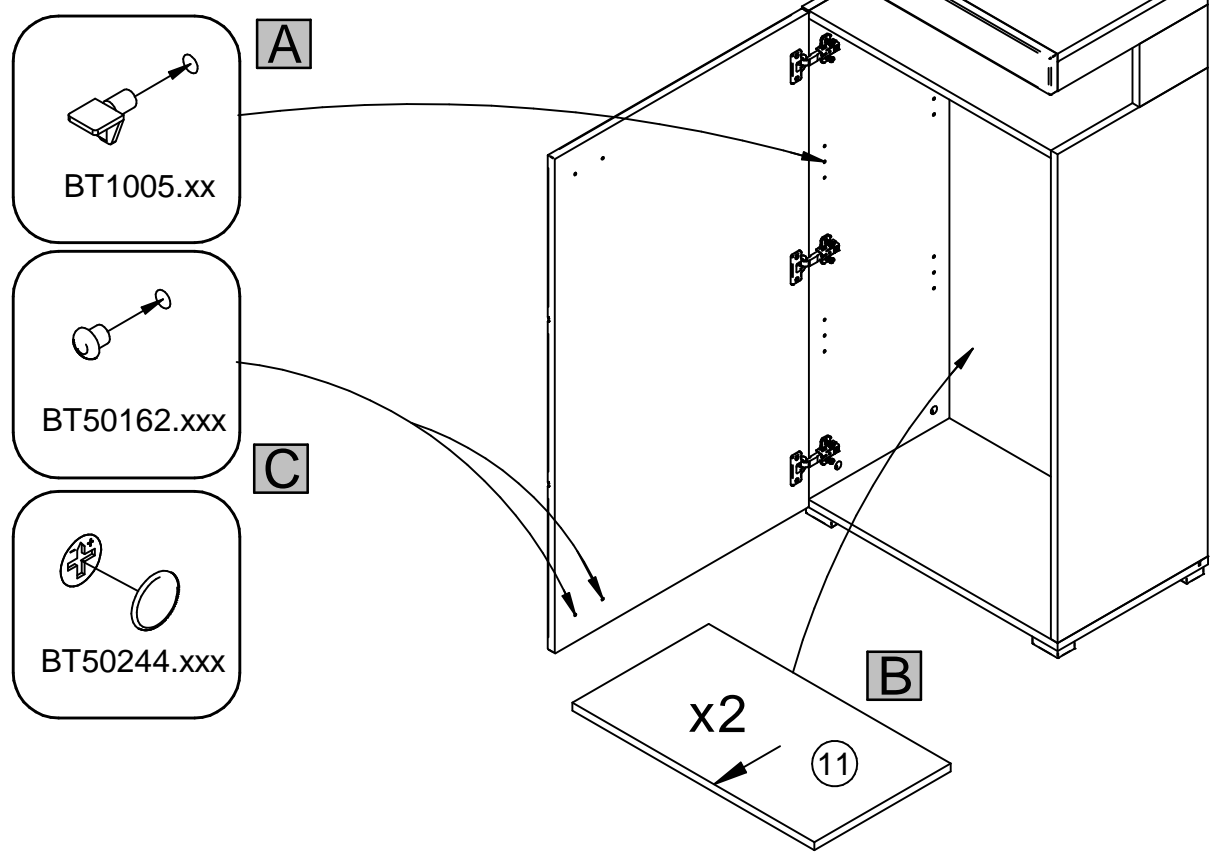

15.

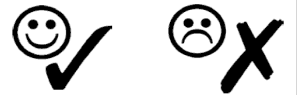
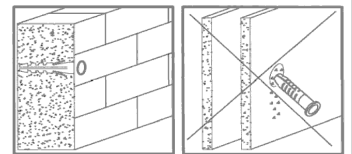
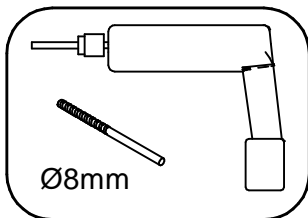
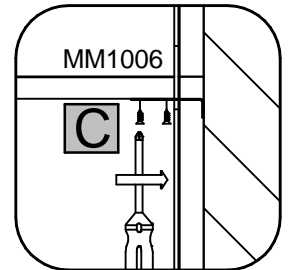
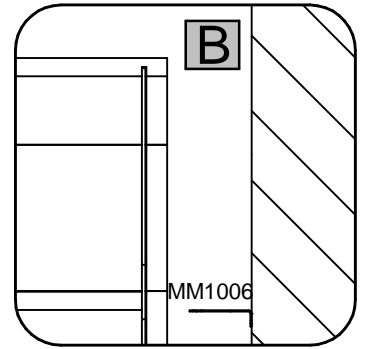
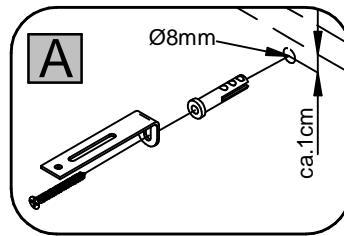
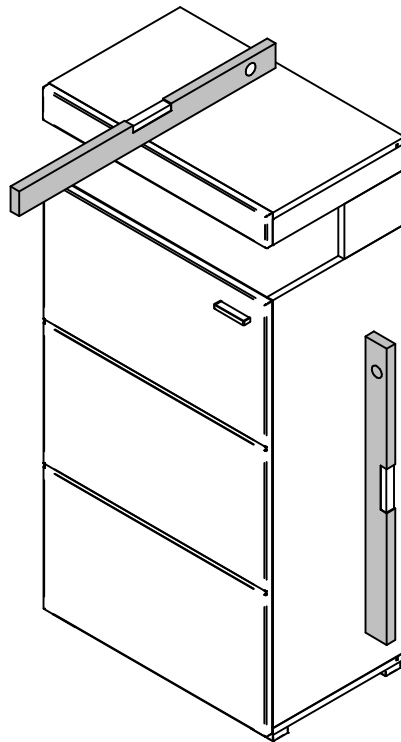
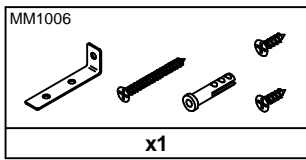

Kombination.

