









NR.5

 3.5x16 S02 x32	 M4x22 S11 x4	 C01 x8	 C10 x8	 C11 x8	 P01 x4
 B01 x4	 M01 x2				

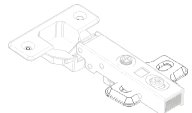

3.

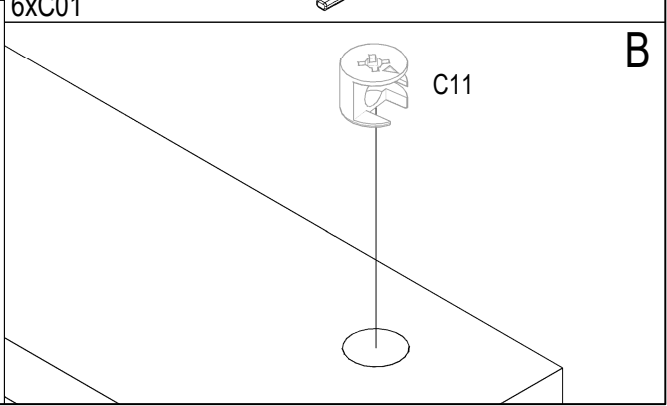
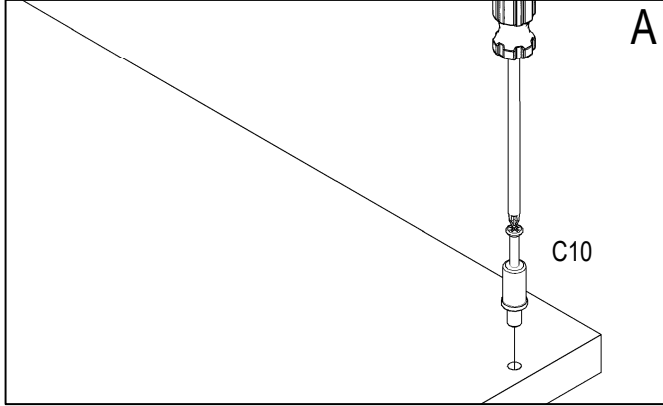
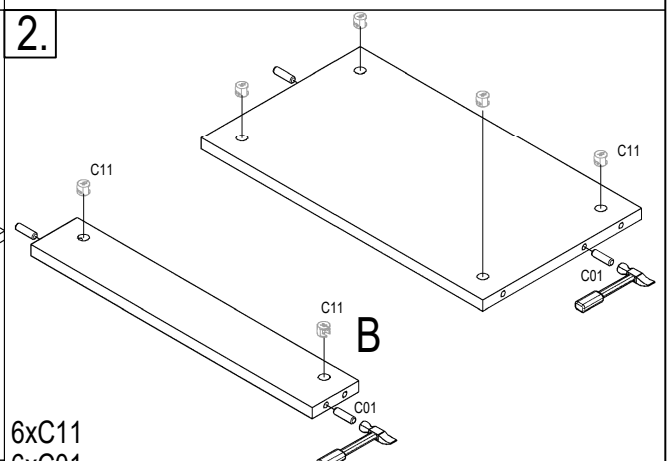
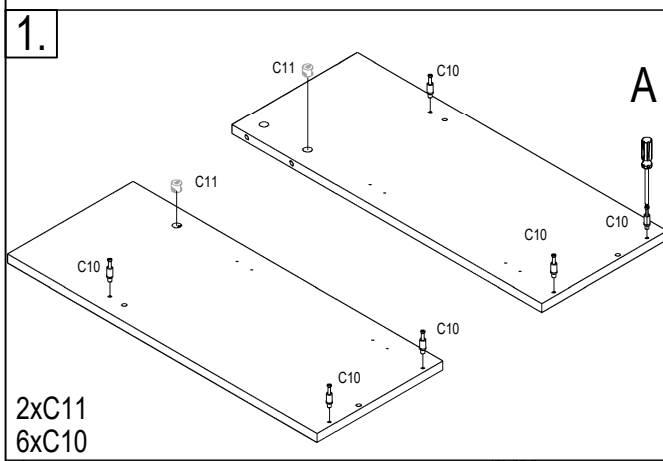
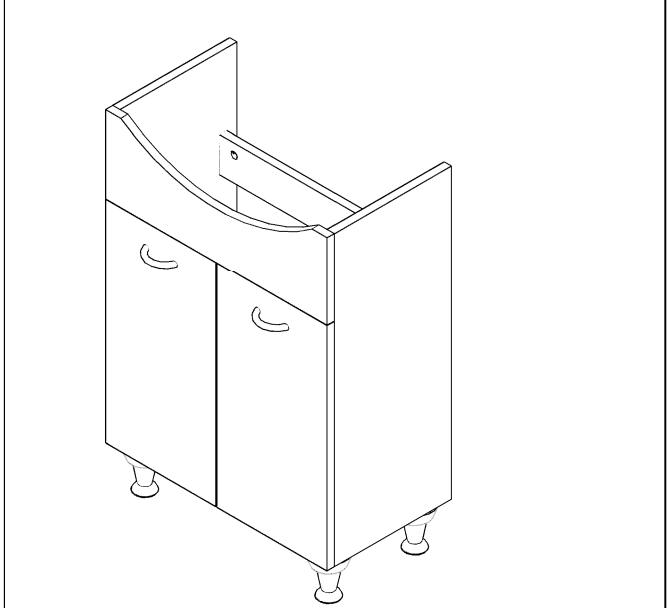
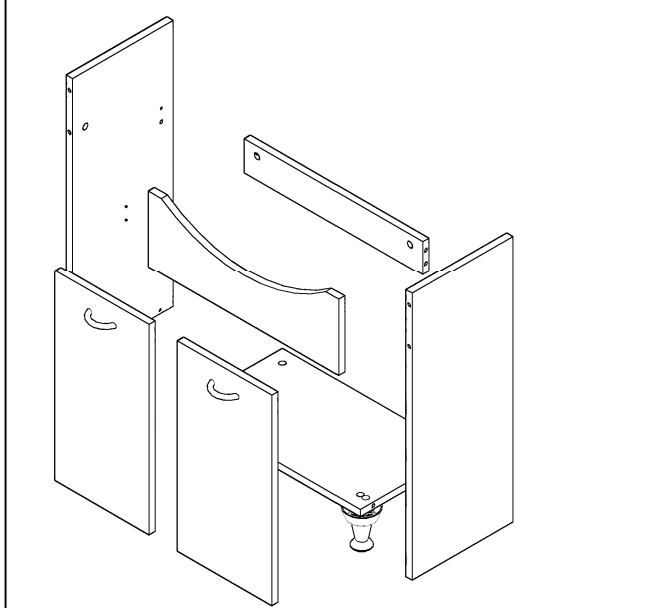
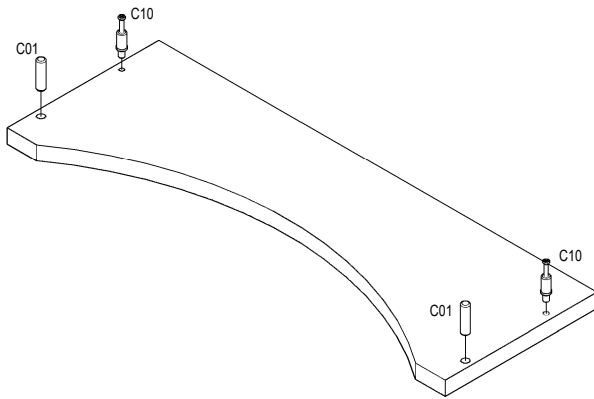

2xC10
2xC01

4.

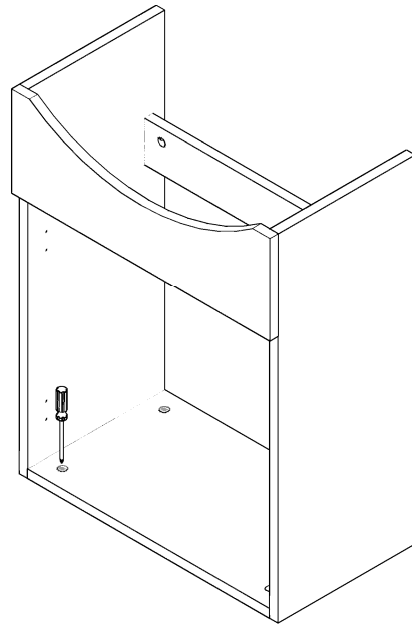

5.

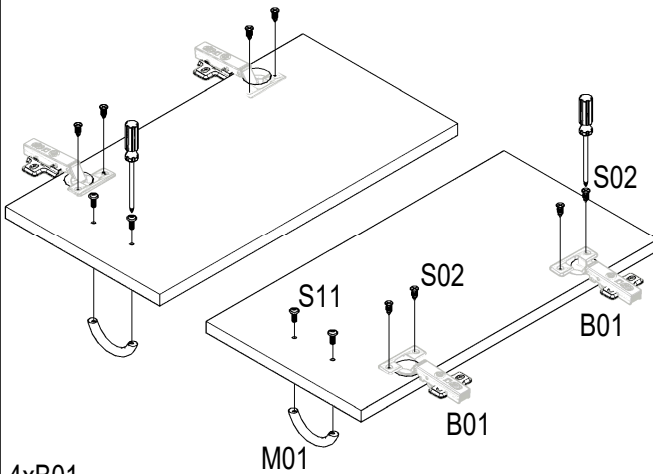

4xB01
2xM01
4xS11
8xS02

6.

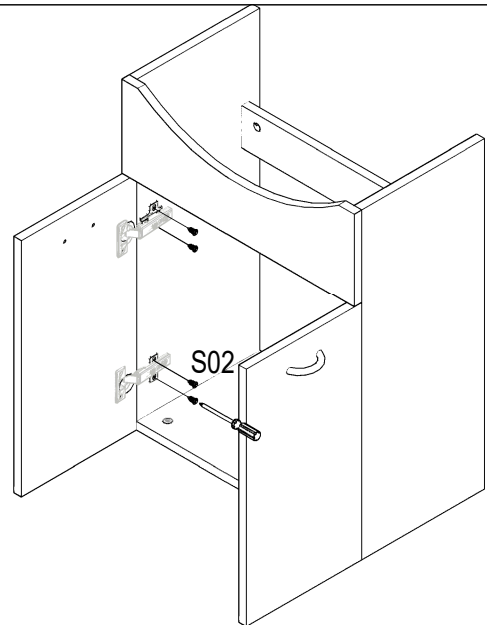





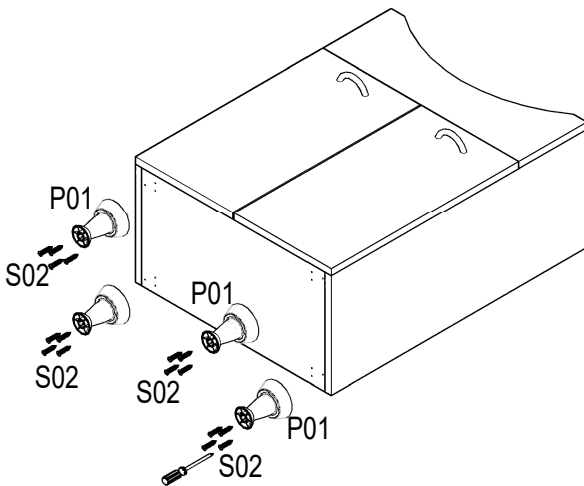

8xS02

7.

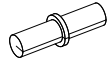

4xP01
16xS02

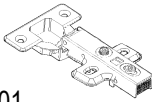
NR.110

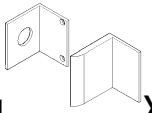
 S02 x54	 S11 x4	 C01 x12	 S21 x12	 C10 x20	 C11 x20
 B01 x4	 M01 x2	 P01 x4	 A01 x4		

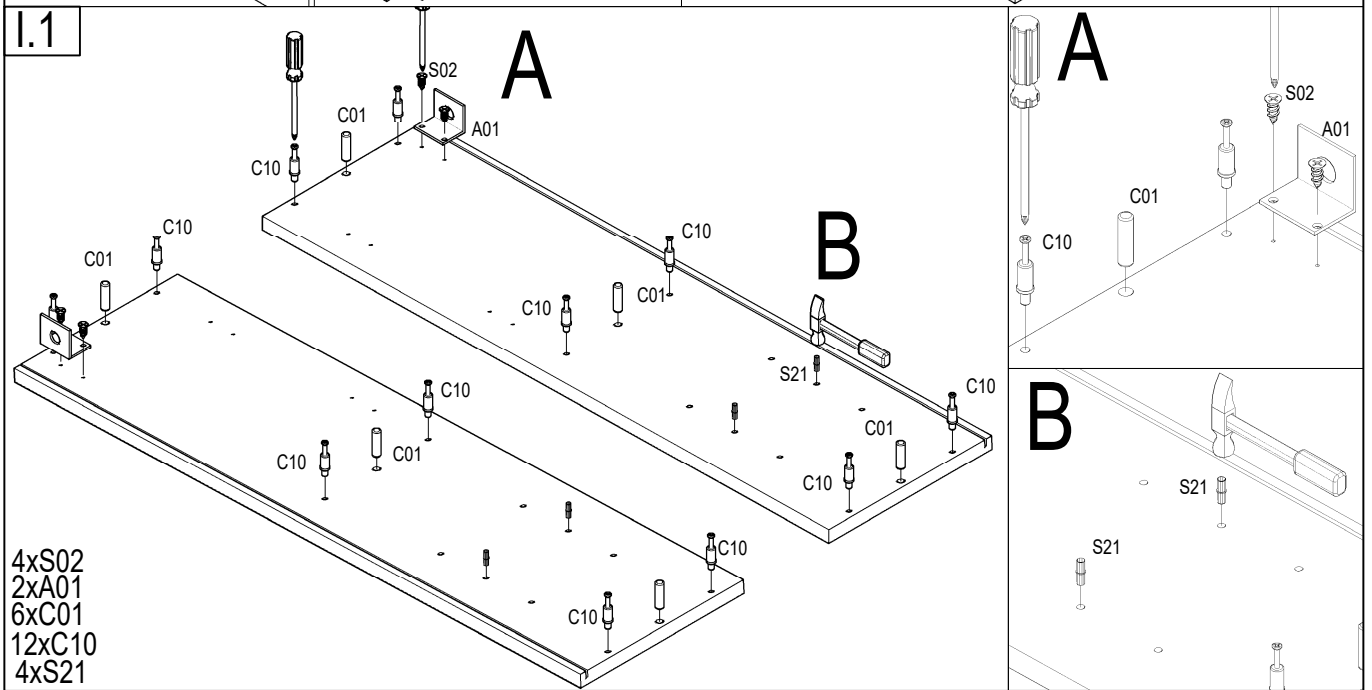
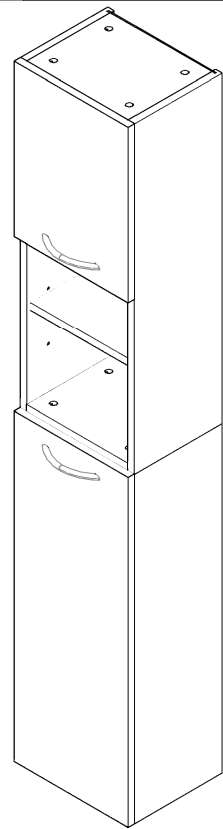
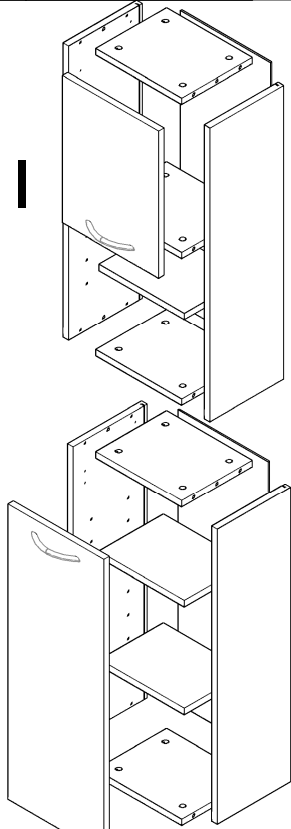

I. 2

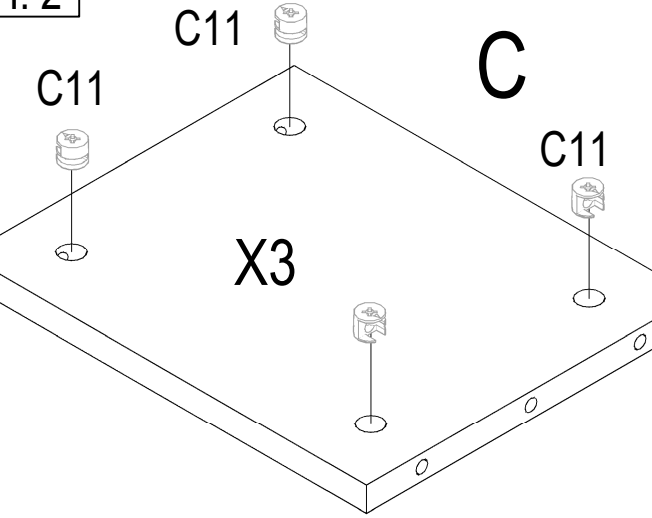

C

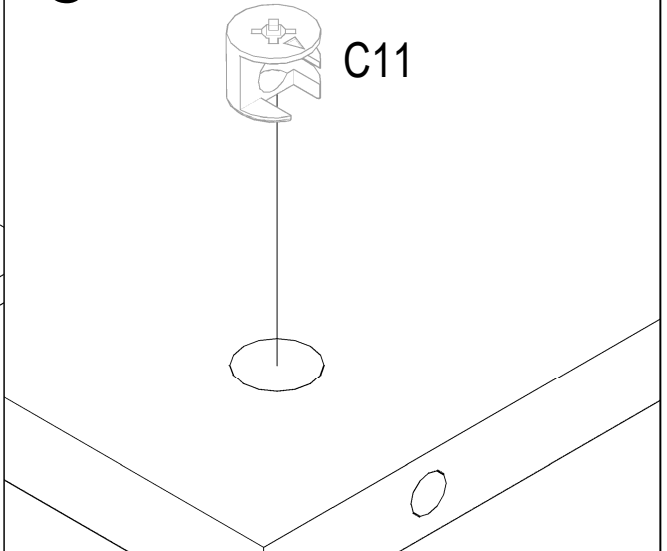

4 x C11

I. 3

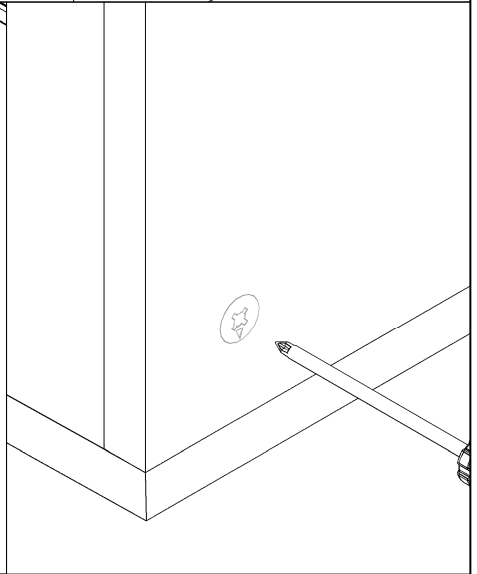
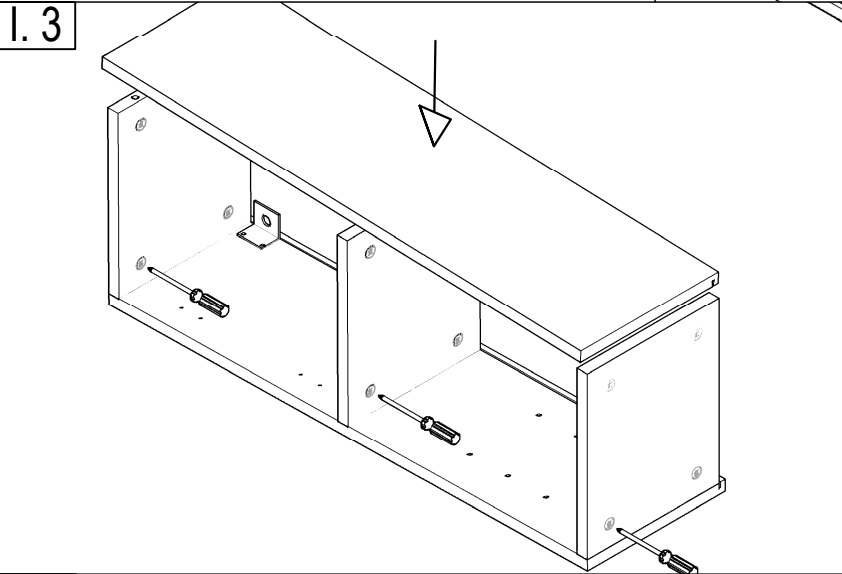

I. 4

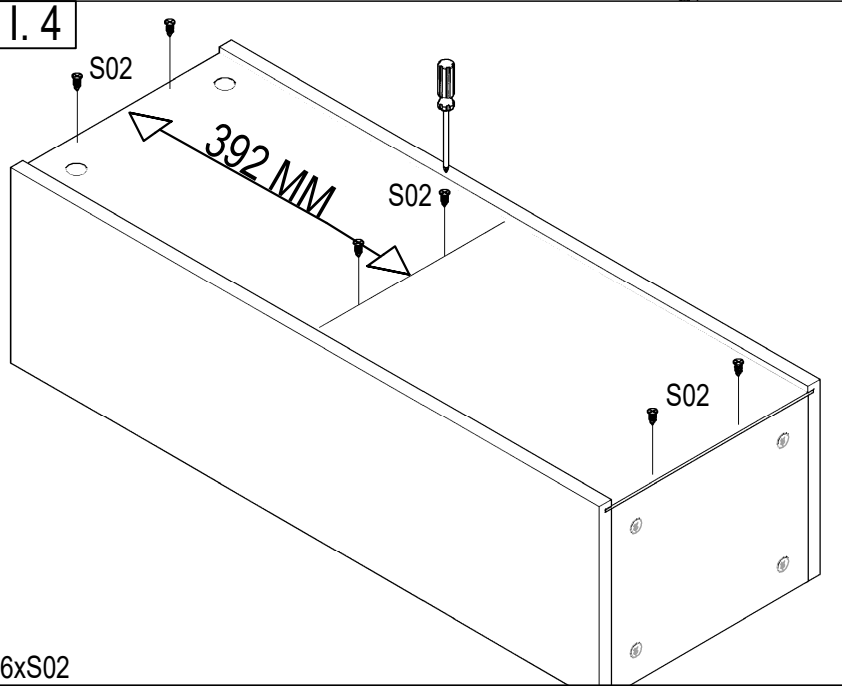

6xS02

I. 5

drill bit 5 mm

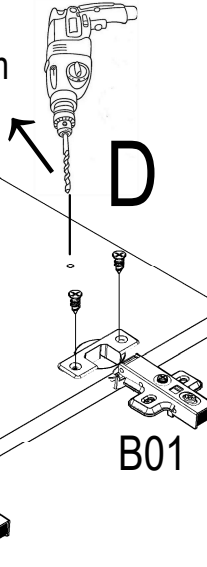

D

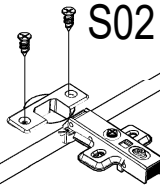

B01

4 x S02
2 x B01

I. 6

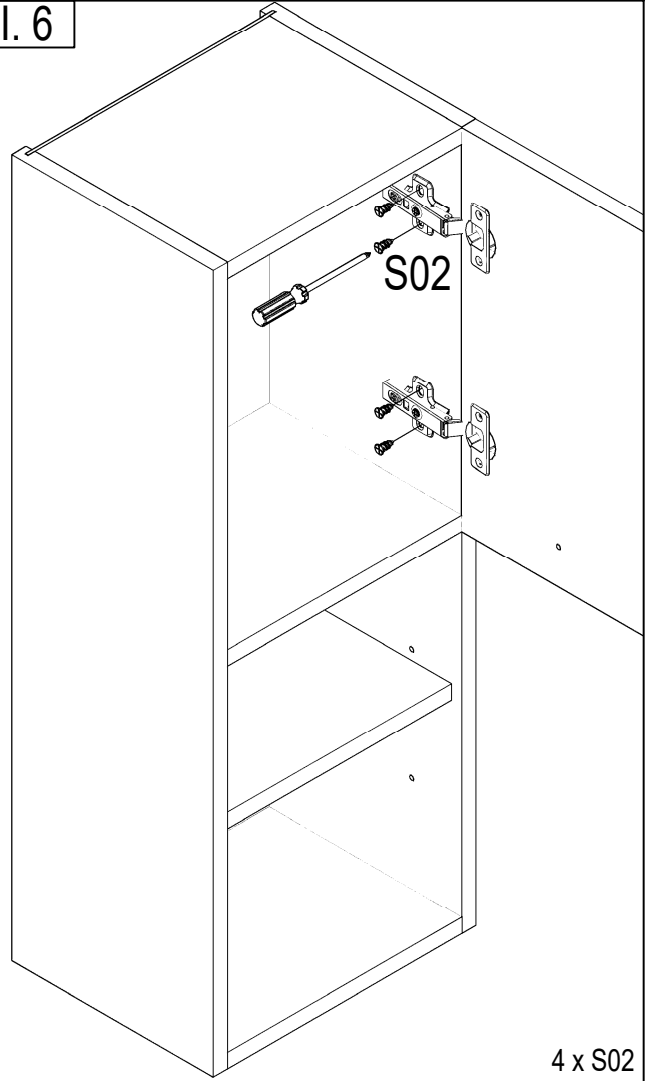

S02

4 x S02

II. 1

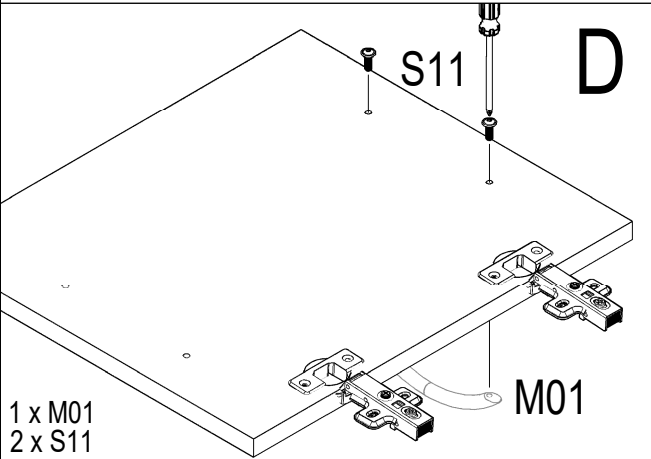

S11

D

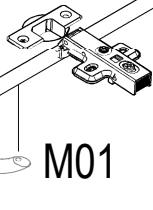

M01

1 x M01
2 x S11

II. 1

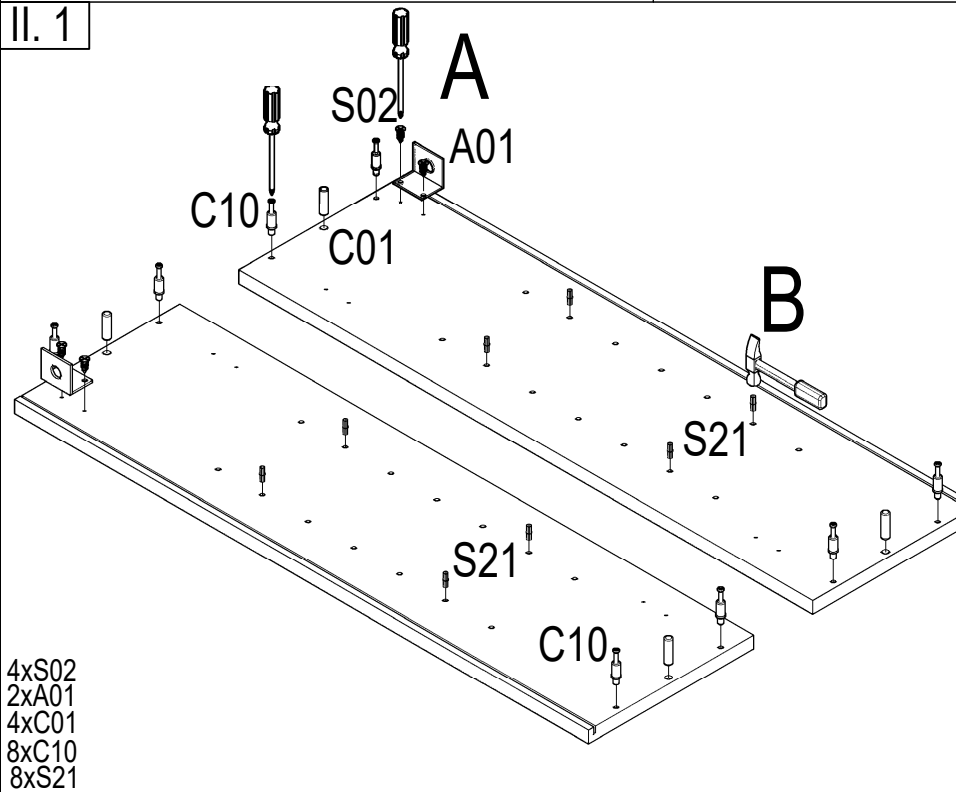

A

S02

A01

C10

C01

B

S21

S21

C10

4xS02
2xA01
4xC01
8xC10
8xS21

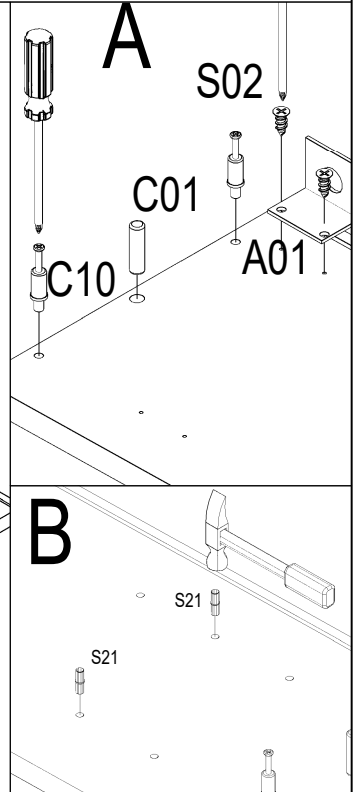

A

S02

A01

C01

C10

B

S21

S21

II. 2

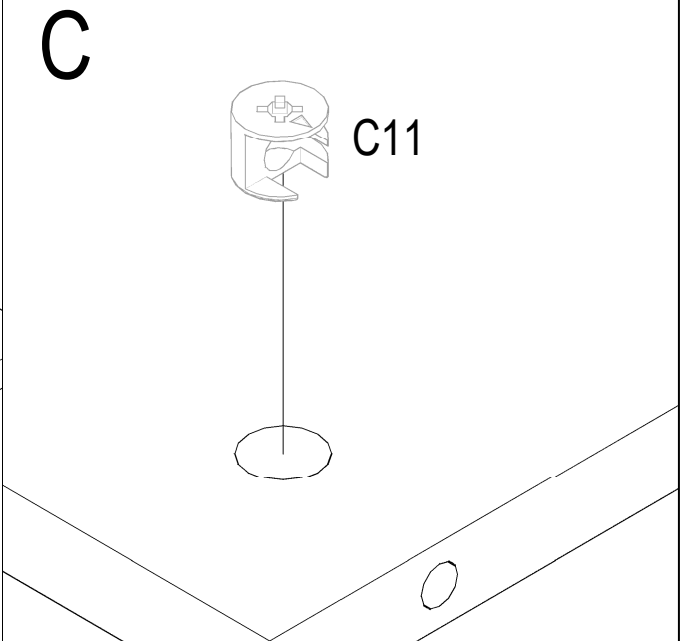
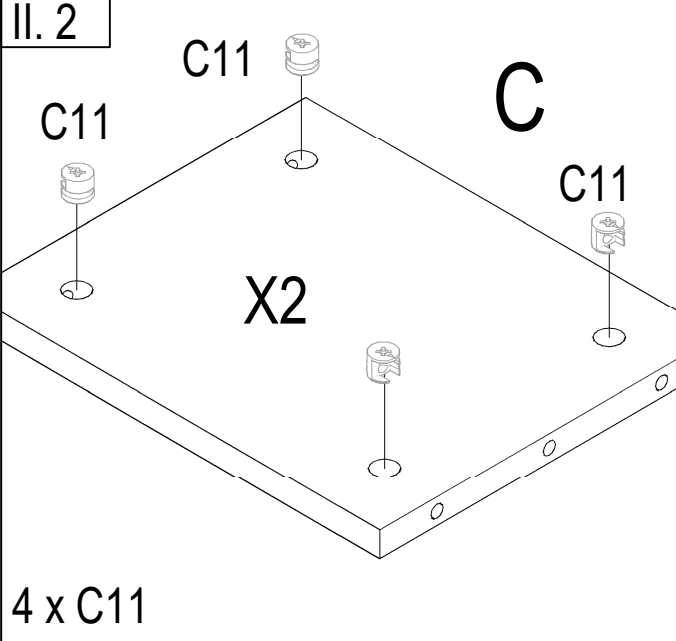

4 x C11

II. 3

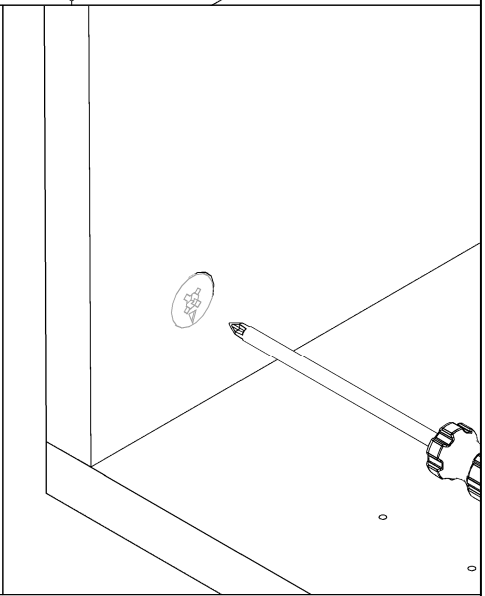
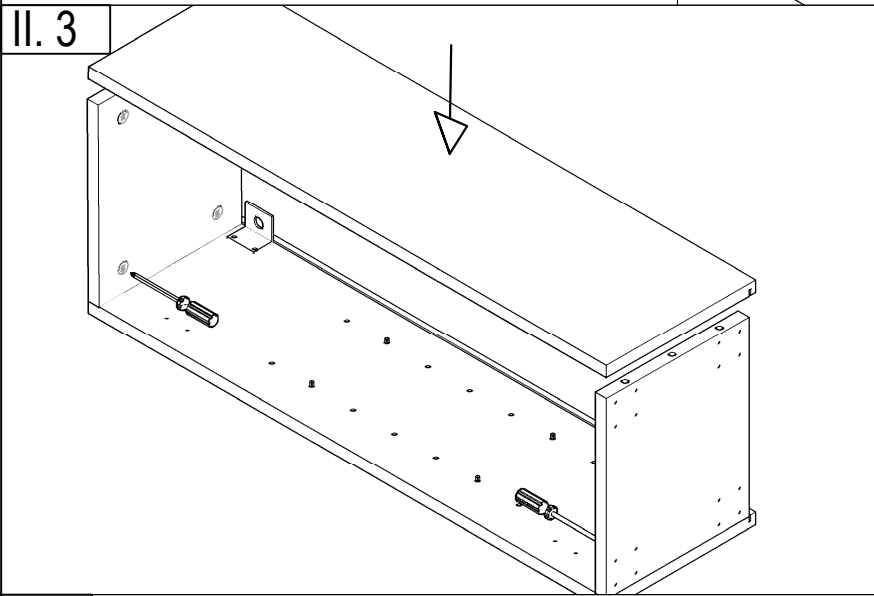

II. 4

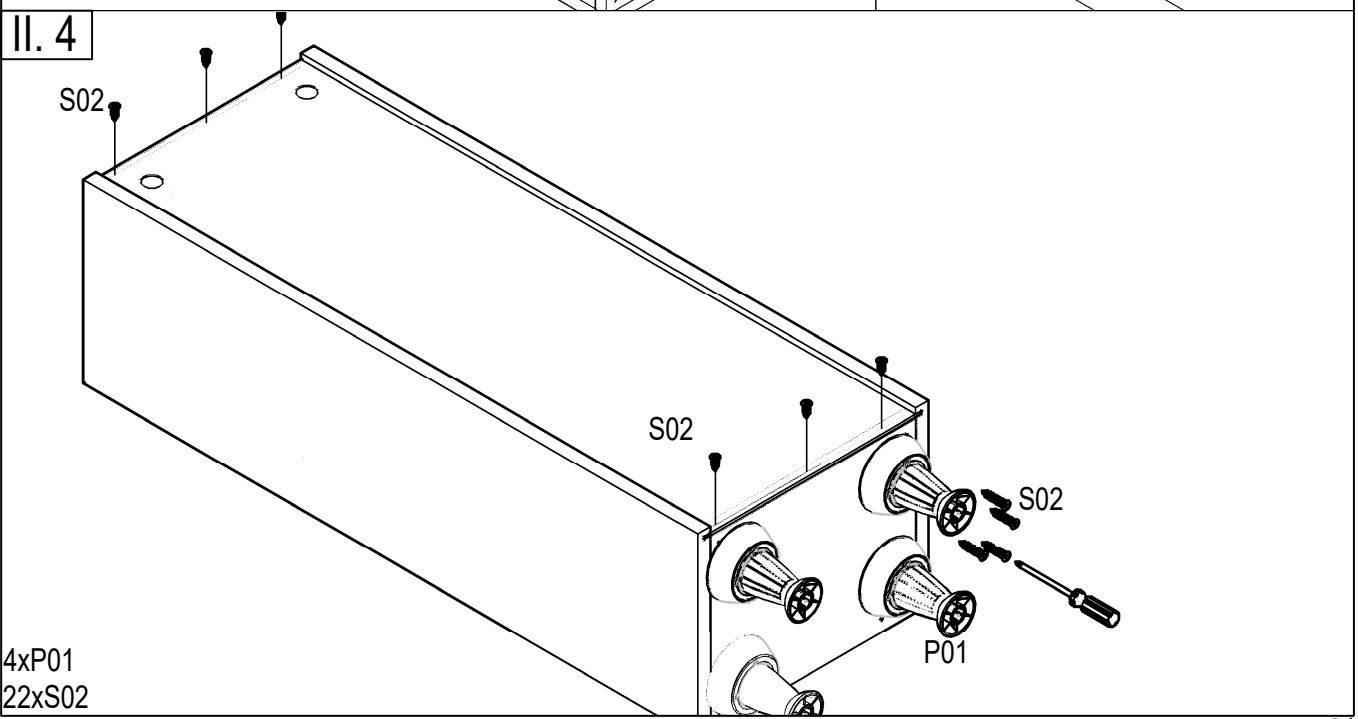

4xP01
22xS02

II. 5

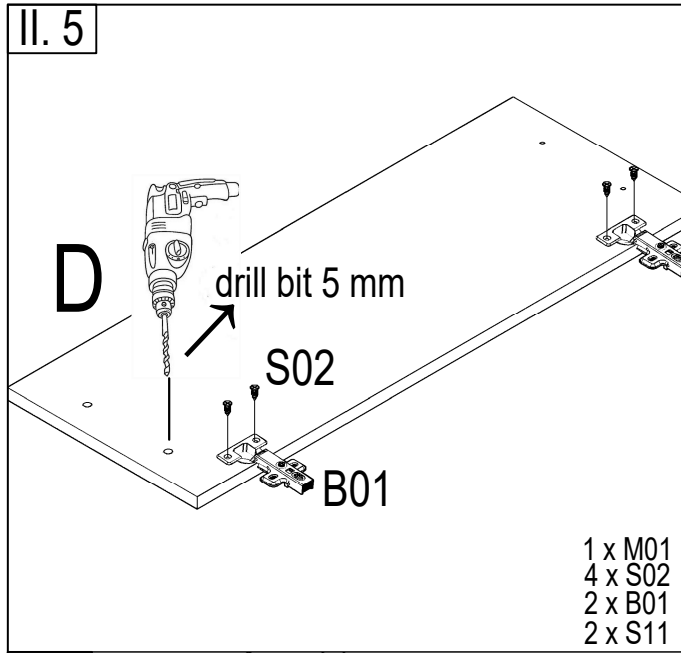

D

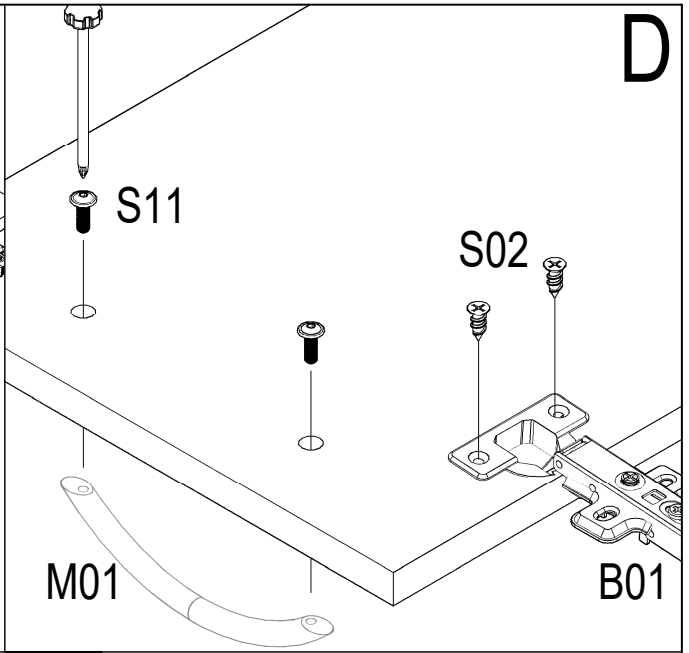

II. 6

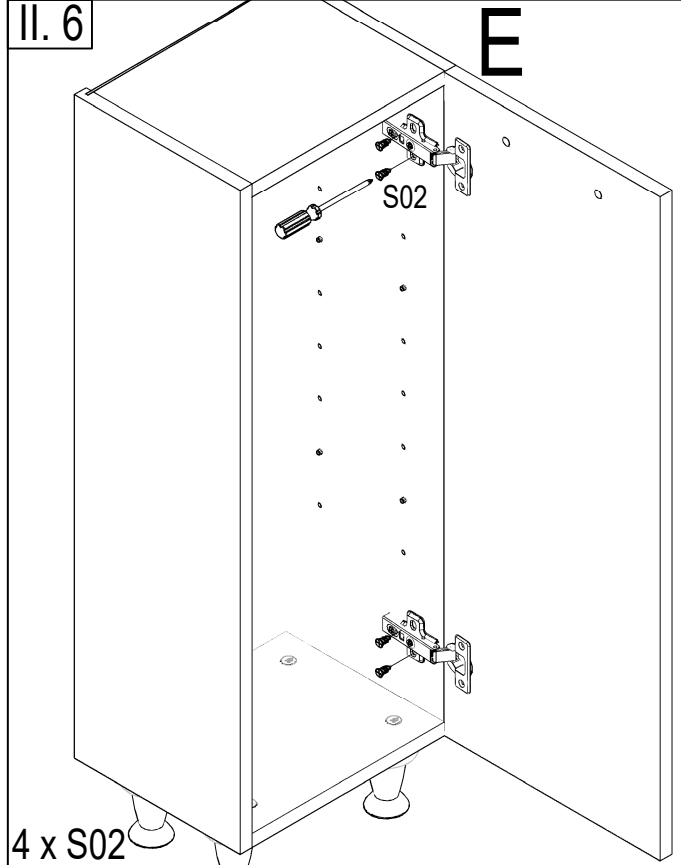

E

II. 7

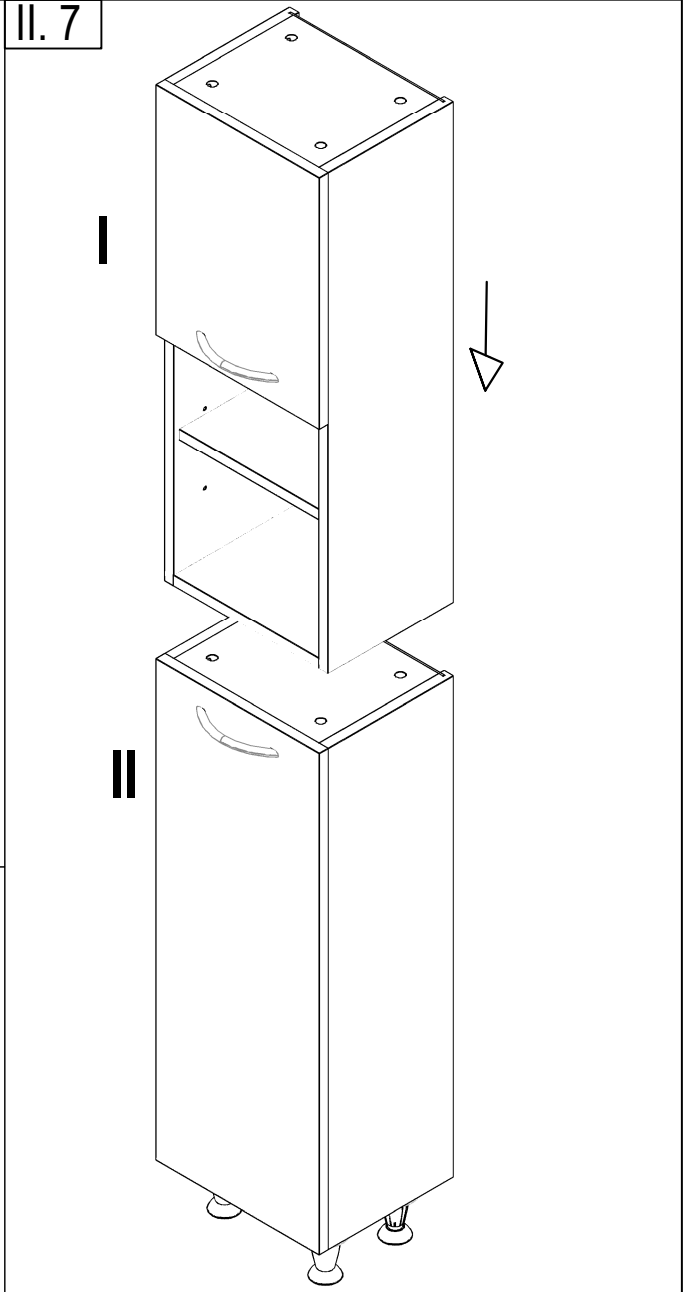

E

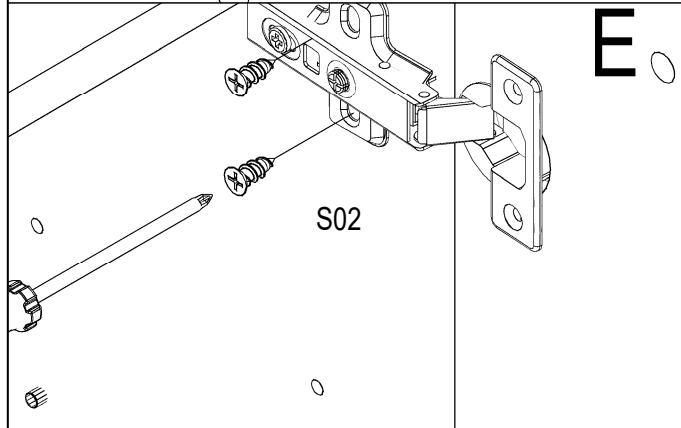

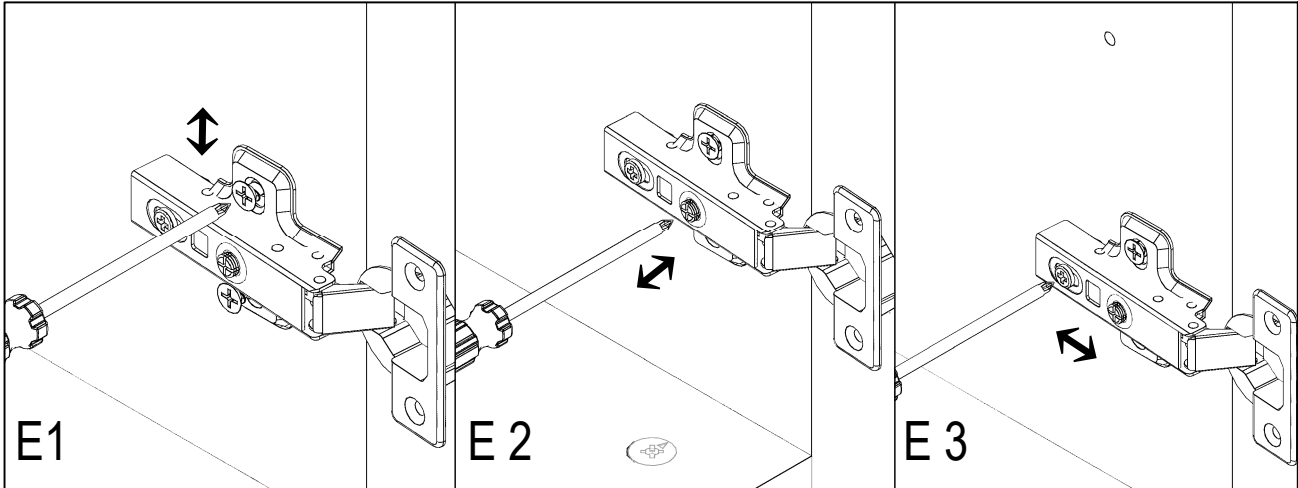

E1

E2







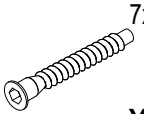

E3

HEIGHT ADJUSTMENT

SIDE ADJUSTMENT

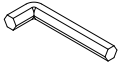
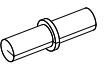
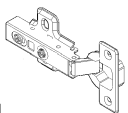
DEPTH ADJUSTMENT

NR.1

 7x50 S01 x6	 3.5x16 S02 x8	 M4x22 S11 x2	 C01 x12	 D01 x1	 S21 x8
 B01 x2	 M01 x1	 A04 x2	 D04 x1		

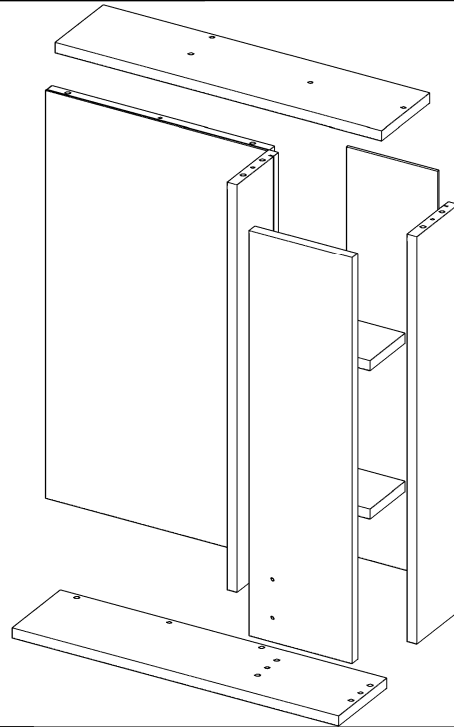
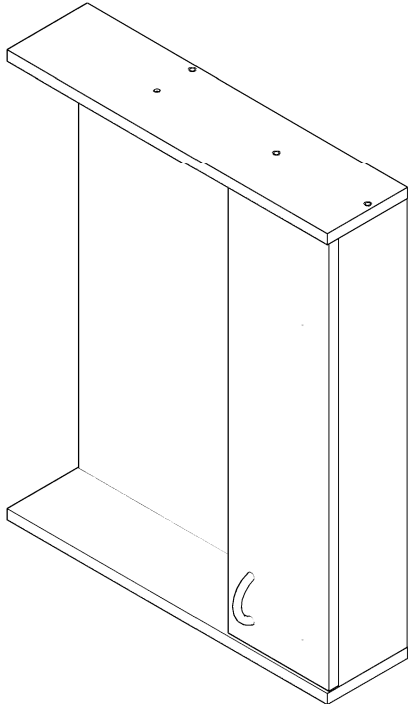

1.

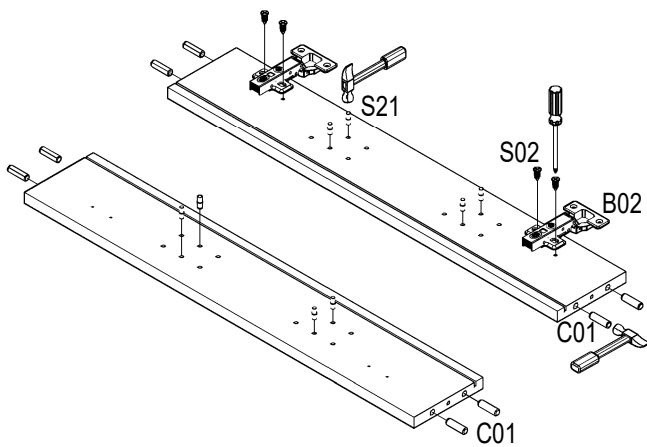

8xC01
8xS21
2xB02
4xS02

2.

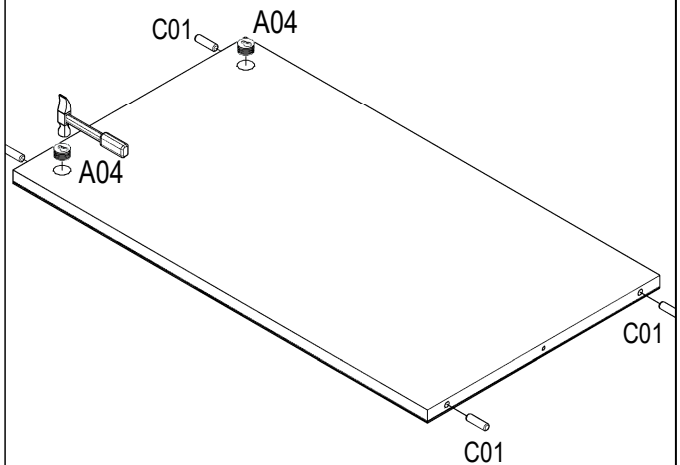

2xA04
4xC01

3.

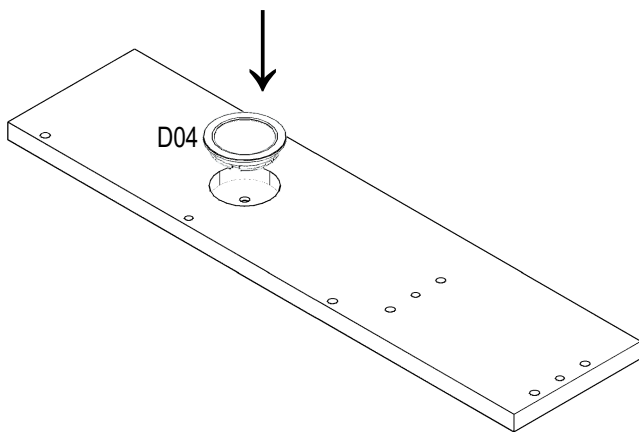

1xD04

4.

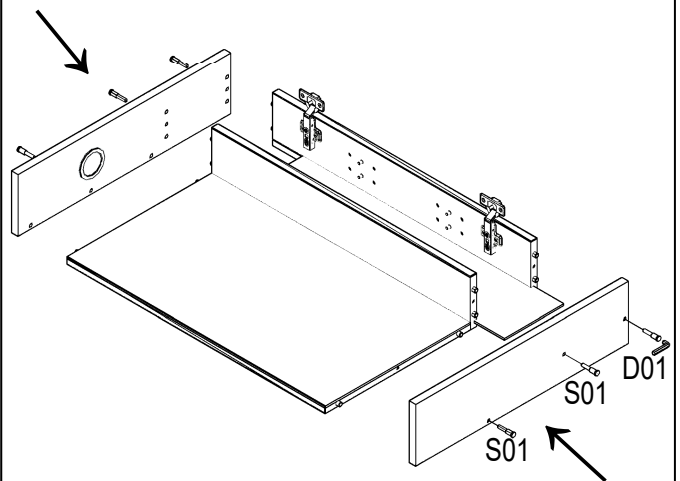

6xS01
1xD01

5.

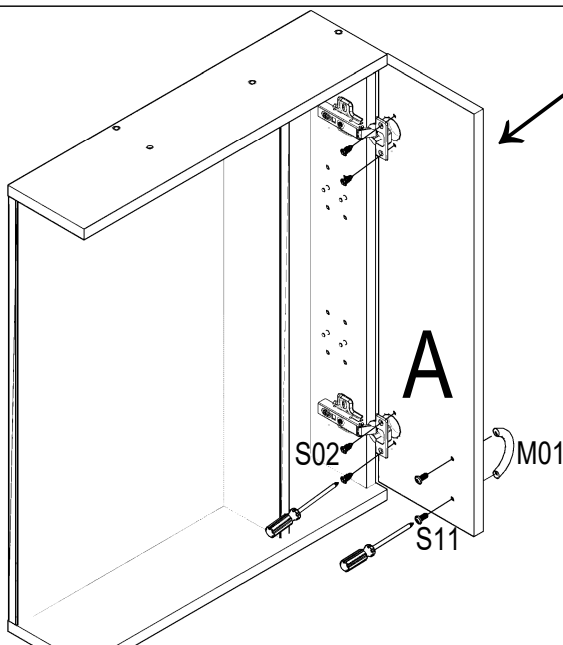

1xM01
2xS11
4xS02

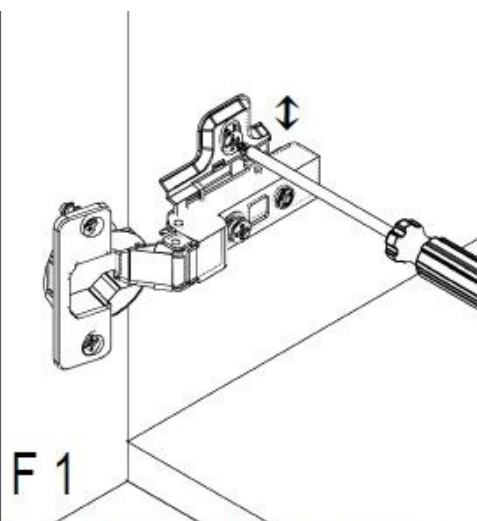
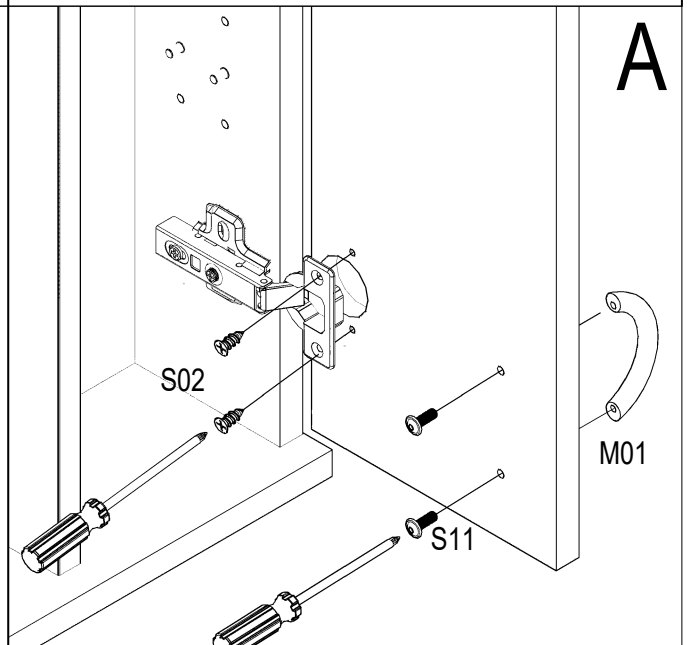

F 1

HEIGHT ADJUSTMENT

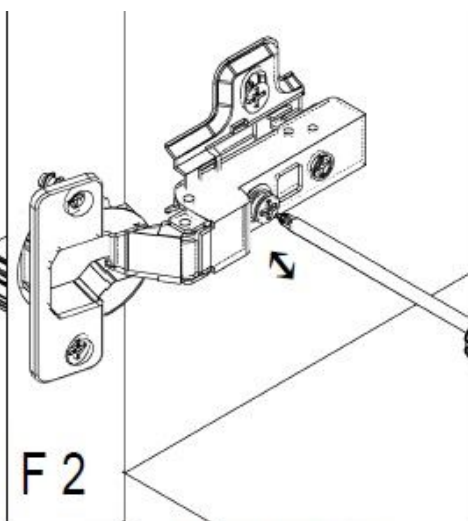

F 2

SIDE ADJUSTMENT

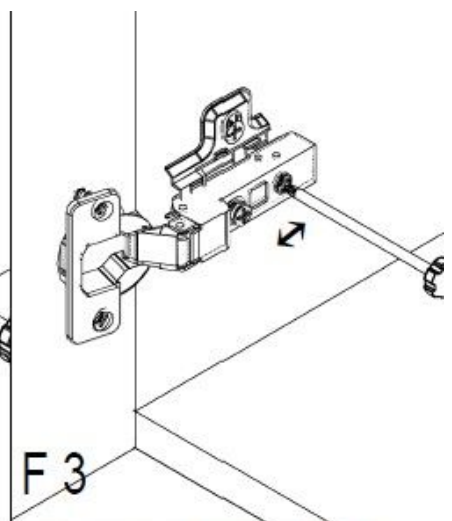

F 3

DEPTH ADJUSTMENT